

Fraser Valley

Milk Break

1980

Milk break



VOL. 6, No. 1 JANUARY-FEBRUARY 1980



Staff and Welfare's good works recognized Coming up: Casino night

A "Big-Hearted Business" award has been given to Dairyland's Charitable Donations fund from the B.C. Heart Foundation. The Foundation, now in its 25th year of operation, recognized several businesses for their continued support. Dairyland employees have contributed \$3500 over the past ten years.

The Foundation stated in its letter of thanks,

"This 'Big-Hearted Business' award is our way of showing how much we have appreciated your interest in our work. It must give you a good feeling to know that there are

thousands of people alive and functioning today who would not be here, were it not for the cardiovascular research which your dollars have helped to support."

The Dairyland Employees Charitable Donations Fund (commonly known as Staff & Welfare) receives \$3.00 a month from its members, \$2.50 of which is allocated to a combination of charities decided upon at each general meeting.

The fund's next venture is a Casino Night on February 16, all proceeds to be donated to the Variety Telethon

which is also held that same weekend. Casino Night will feature a variety of games of chance and an auction for prizes at the end of the evening. It follows the annual business meeting at 6:00 p.m. in the W. J. Park Room at Burnaby.

Photographed with "Big Hearted Business" award are a few of Burnaby's Staff and Welfare members. Back row, from left, Greg Singleton, Jim Detries, Gerry Amantea, Ted Salmon, Bert Richardson, Tom Low, Bud Mason, Ruth Schafer, Bill Osborne. Middle, from left, Cheryl Eckhart, Peggy Homewood, Karen Andersen, Joe Jessup, Bill Hawes, Peter Braun. Front, from left, Roz Lincoln, Deborah MacDougall.

Your Opinion

The United States plans to boycott the 1980 Summer Olympic Games in Moscow if the Soviet Union does not withdraw from Afghanistan. Do you think that Canada should boycott the Olympics?

In a chance sampling taken at the Burnaby plant January 25th, 1980, 53 out of a total 84 people (63%) said 'yes' we should boycott the Games. Taking the opposite view 'no' we should not boycott the Games, were 22 or 26%. Undecided numbered 9 (11%). Among the yes votes many people expressed the feeling that the Games should be held in a different country.

Here are a few random comments:

Jim Defries—I wouldn't like to deny the athletes the chance to compete and waste all that training and expense for the sake of the politicians.

June Florczyk—The Olympics should be held in some permanent place such as Greece.

Rene Gribble—I would rather see countries apply social and economic sanctions than take military action.

Wayne Taylor—I would not be as ready to boycott the Games as some others.

Roger Parnall—Why should we go along with the Soviet Union when we don't approve of their actions? This situation goes beyond politics or sports, right down to the common person.

Bob Simpson—A boycott accomplishes nothing except hurt our athletes. Canada or the U.S. can't afford to reorganize another Summer Games.

Randy Williamson—I don't think the average Russian citizen is well informed about world opinion. A boycott of the Games would bring this close to home.

Jim Donaldson—The idea that sports and politics shouldn't mix is untrue—they are one and the same in Communist countries.

Don McQueen—I have mixed feelings, but I don't believe the Olympics should be used as a weapon.

Joe Robinson—Why didn't they withdraw from the Munich games, after the terrorism incident if international empathy is of such concern?

Ruth Morrison—Drastic measures are necessary to stress the very serious situation which exists in the world today.



Doug Wilson's gleaming '39 Packard is increasing in value.

Vintage car last of an era

Parked in stately elegance by the beachfront at White Rock—although you can almost see the machine guns blazing—is **Doug Wilson's** pride and joy. Doug, the Assistant Safety Supervisor at Burnaby, bought this 1939 Packard six months ago. It is a rare model, the last of the pre-war era.

Doug had always wanted to own a vintage car and when this one was advertised for sale, he edged out the other prospective buyers to get it. Doug says it drives "like a dream" and was in really good shape when he made the purchase last August. All it needed were some minor electrical repairs and a restoration of the paint to get it looking as good as when it was driven off the lot.

Doug does all his own maintenance. Previous experience owning other vintage cars such as a Model A, a '23 Oldsmobile and a '33 Frontenac, has given him a store of knowledge about the engines and parts which differ quite a bit from the modern car.

The speedometer on the Packard reads only 15,000 miles which accounts for the excellent condition throughout. Doug doesn't know much about its history, but he is presently digging back into Motor Vehicle Branch records to find out about previous owners. Any car which is over 30 years old and in running condition is considered a vintage car and is given special MVB licence plates.

Doug says the car's value is steadily increasing. He paid over \$6,000 for it six months ago and estimates its present value at above \$10,000.

When he takes the Packard on special outings, it attracts a great deal of attention, especially among older people who love to stop and reminisce about the cars they used to have. Doug usually offers them a ride in it.

Others who enjoy a drive are the Dobermans, Ilsa and Dorf who, when clean, sit serenely in the back seat and behave like model passengers.

Used golf balls for Christmas fund

During the Christmas season, **Ralph Ruddy**, Retail Operations Assistant, had a brisk trade in golf balls going on in the drivers' room at Burnaby. The balls, some only slightly damaged, were brought in by checker **Roy Elford** who goes out collecting them in his spare

time. He apparently knows the location of some extremely difficult holes on Vancouver Island. Ralph bagged up the balls and sold them three or four for \$1.00. He collected \$105 for a generous donation to the Tiny Tim Christmas fund.



Top, Frank Noble; bottom, Reg Peckover.

Accidents 99% preventable

The magic word in the FVMPA Safe Driving Program is "preventable." The committee that meets every two weeks to determine whether accidents were preventable or not strictly applies this rule to each circumstance: "*A preventable accident can be avoided by anticipating the hazard before it is too late to take evasive action.*" How to do that? Here are some driving tips by fleet Safety Supervisor, **Omer Tupper.**

- Avoid backing accidents by parking so that your initial movement is forward. If a vehicle obstructs your forward movement after you have parked, you can still avoid a backing accident by walking behind your truck from the sidewalk to the left corner of your truck. Observe the traffic pattern, enter the cab from the driver's side, immediately start backing and continue to watch the traffic with your mirrors. This not only keeps you aware of cars parking behind you, but it also alerts other drivers of your intentions to move your vehicle.

- Brakes lose some of their holding

effect when backing up. Brake shoes pivot on the forward side of the drum. When the wheels are turning forward the movement tends to jam the shoe into the drum. When the wheels are turning backwards the movement tends to move the shoe away from the drum. This requires more pressure to force the shoe against the reverse motion of the drum. This is why we frequently have loaded trucks back into carport eaves, as the drivers fail to realize that it takes longer to stop when reversing.

- Most emergency brake drums are mounted on the drive shaft. It is a single drum with brake shoes. If an axle breaks, the drive shaft can remain stationary and the wheels are free to roll, so don't rely on emergency braking.

- Headlights should be used in any situation when vision is reduced — either from rain, fog, snow, dust or during dawn or dusk. It may not be necessary for your vision but it helps other motorists to establish your location and speed.

Ice cream carton takes a silver

Dairyland's two litre ice cream carton has just won the 1980 Silver Award for packaging excellence in the folding paper box category in Canada.

This new package combines the Dairyland corporate farm scene featured on all milk cartons, along with the mouthwatering colour photographs of the ice cream inside. This improves dramatically on the first metric cartons which were rather utilitarian in accordance with the consumer packaging regulations then in effect. It was felt that the packages did not do justice to the high quality of the ice cream.

Since that time however, the guidelines have relaxed and Dairyland's marketing department took the opportunity to produce a really eye-catching package.

Most consumers associate Dairyland with milk but not necessarily ice cream. The new carton does achieve this stronger corporate image. In combination with a major TV campaign last fall and a strong sales effort, Dairyland ice cream volume has increased by 9.06% over 1978.

The Marketing and Sales department is continuing its effort to improve brand awareness and gain a better share of



George Hrennikoff with award winning ice cream packages.

the ice cream market. Positive results are anticipated again in 1980.

The new award winning package was designed by Sommerville Belkin Industries Ltd.

Retirements

Frank Noble of the Burnaby Boiler room retired on December 19th, after seven years with the FVMPA. Frank has been the plant's Chief Operating Engineer for the past six months. Although he is officially retired, Frank is still working as part time holiday relief in the the boiler room.

Reg Peckover is planning a trip to his old homeland England as an early retirement project. His last day at the dairy was January 9th, after 28 years in the Distribution department. Reg covered a wide territory in the retail routes which he held all over the city of Vancouver. He will probably have more time now for his hobby—fishing.

Staff deaths

We regret to report two deaths among the FVMPA retired staff members. **Dennis Bagley**, a Burnaby ice cream driver who retired in 1972, died this past September.

Tom Cannock, who also died in September, was a former Eighth Ave. plant retail driver and a member of the Quarter Century Club.

Gregerson, McCrabb lead Christmas retail sales

A December-long Christmas promotion aroused keen competition among Retail's driving staff. The best results were shown by Bill Gregerson and Jim McCrabb who retained the top sales spot for the second year in a row.

Business ran smoothly through this busy month and particularly on the "Double Days". Both retail drivers and supervisors expressed their appreciation for the efforts of checkers and production people who did an excellent job in providing product and putting up loads.

A record for number of units delivered from a retail truck on a single day was set by **Rick Worsley**, Valley Route 319. Rick put off 3541 units on

Saturday, December 22nd. Average for that day was 2327.

Top Ten Routes

	Driver	Relief
476	B. Gregerson	J. McCrabb
319	R. Worsley	D. Moore
431	P. McNeely	W. Wendland
478	C. Dovey/ R. McLellan	K. Saunders
320	J. Masterman/ E. Hopko	R. Johnston
318	D. Gibbs	S. Wilson
428	G. McKillop	D. Dixon
456	C. Randall	L. Egley
480	J. Gibson/ R. McLellan	J. McCrabb
482	W. Taylor	R. Bjarnason



(l-r) Jim McCrabb, Bill Gregerson.

Marketing appointments

New sales and marketing appointments were announced in early January. **Lee Alberts** has been appointed Wholesale Accounts Manager, FVMPA. Lee's responsibilities will include the direct supervision of our Prairie Sales Force and the control of all wholesale accounts in Alberta, Saskatchewan and Manitoba. Lee will also supervise the sales of our portion products (Gasti), maintaining close liaison and full responsibility for all our portion customers.

Ted Harford moves to the position of Sales Administrator, Pacific Milk

and Armstrong Cheese. Ted will be responsible for the Sales Order Desk, our customer co-operative advertising and merchandising programs and compilation of all statistical data relative to Pacific and Armstrong Sales programs. In addition, Ted will be involved with certain Head Office sales responsibilities in the Lower Mainland.

Bob Cooper continues his responsibilities as Wholesale Accounts Manager, however, will now assume the supervision of our B.C. Interior sales force as well.

Burnaby roof lures all sorts



If this bird decides to return to its nesting place we may see it again in the Spring. It is a Killdeer, which was spotted and photographed on the Burnaby roof by Engineer **Jim Byres** last Spring. Usually these birds do not like a city environment, preferring to nest in flat fields in the country. If you look closely you can see the speckled eggs; unfortunately, these were eaten up later by crows or seagulls. The Killdeer is famous for doing its "broken wing" act when disturbed.

Exercise the easy way

Ever had a big lunch, then try to "run it off?" Rather difficult isn't it? However, there are easier forms of exercise than running . . . exercises that can be just as beneficial.

Did you know that stair-climbing and walking are two of the simplest and among the most effective forms of fitness exercise generally, and are effective as part of a weight control program as well? What's more, both forms of exercise offer working people a chance to get or stay in shape.

Dr. Lenore R. Zohman, a respected North American Exercise Cardiologist, offers this advice: "The type of exercise that leads to the most appropriate kind of fat loss is *easy exercise*, carried out over a *long period* of time. This is particularly important for overweight people, because for many of these individuals, intense exercise is risky."

Weight Watchers Information Centre



Wendy Hurst

PUBLISHED FOR THE INFORMATION OF THE EMPLOYEES OF THE FRASER VALLEY MILK PRODUCERS' ASSOCIATION, 6800 Lougheed Highway, Burnaby, B.C. Edito.: Verlie Bousfield, Mailing Address P.O. Box 9100, Vancouver, B.C. V6B 4G4 Telephone: 420-6611

Milk break



VOL. 6, No.2 MARCH-APRIL 1980



Samples of UHT milk are tasted by (l-r) Ursula Cempel, Carmella Buechert and Laurie Britton. The product, first of its kind in B.C., is expected to go on the market in mid-June.

U.H.T. lines soon to roll at Abbotsford

The word is "U.H.T." and it represents a vast new undertaking by the FVMPA. Soon, our Association will be producing and selling "long life", ultra high temperature (UHT) milk, an exciting innovation completely new to B.C.

Long life milk is simply fresh, natural, top quality milk which has been treated with a special heating process to extend its keeping qualities. Long life 2%, for example, will stay fresh without refrigeration for up to four months. Unlike some of its predecessors, this new product tastes good and is intended for drinking and normal fresh milk use. It has nothing added except Vitamins A and D. The process is essentially an ingenious form of pasteurization (see insert next page).

Long life products have a ready market in remote areas that have limited access to refrigeration or where people may shop only once or twice a month. They will also be convenient for camping, boating, vacation homes and as a back-up in the kitchen. Ships at sea for extended periods of time will probably find many uses for the products.

The full market for UHT milk will be discovered only as it gradually becomes more familiar to consumers. We anticipate that sales for long life milk will account for about four to five per

Announcement

The applications by the Office and Technical Employees' Union, Local No. 15 and Teamsters, Local Union No. 464, for certification of an office bargaining unit, were considered by the Labour Relations Board of B.C. The board has concluded that neither union applied for an appropriate unit of staff and therefore rejected both applications.

Staff star in dairy industry TV documentary

"A day in the life of a dairy farmer" was the theme of a recent CBC TV program that visited the farm of FVMPA member **Bob Robertson** of Delta. The show, Sunday Magazine, which presents one and a half hour live coverage weekly of general interest topics, is hosted by **Bob Switzer** and was aired March 16th.

A tour of the Robertson dairy farm with a glimpse of what it takes to manage a 50 cow herd and the lifestyle of Bob and his family, were presented through interviews and film sequences. Bob's wife **Vera** also described her job as a farm wife and her special interest in horses.

Dairyland employees **Tom Low** and **Earl Webster** gave live interviews on other aspects of the dairy business. Tom outlined the work of a dairy farmer within a cooperative group such as the FVMPA, gave a description of the Association's collection of dairy antiques and viewed the future of the dairy industry, appropriately, on location in the calf barn.

Earl, a former driver salesman with 50 years in the dairy business, recounted some of his early experiences and described what it was like to deliver milk "way back then".

So that the live interviews could be
Continued page 4

Abbotsford plant, continued

cent of total milk sales within the next two years. As a premium priced product, it will cost about 7 or 8 cents per litre more than fresh 2% milk in a one litre carton.

Quebec has produced long life milk for about four years and recently a UHT plant has been established in Alberta. In building a new plant here with the facilities for producing UHT products, the FVMPA ensures B.C. consumers that they will utilize the milk produced in our province to the fullest extent. Otherwise, with the varying price of fluid milk throughout Canada, it is possible that milk from outside B.C. would gain access to this market.

But another aspect in establishing a UHT business is the potential that it

or in the store. It will also mean fewer deliveries and saved fuel.

Our equipment for UHT products will share quarters at the new plant at Abbotsford with facilities for processing Armstrong label Cheddar. The building, next door to the Pacific Milk plant is almost complete and equipment is now being installed, tested and put into service. We hope that long life products under the new "Dairy-Maid" label will go on the market in mid-June.

The first products off the line will be basic ones—2% milk and chocolate milk in one litre and 250 ml sizes and light cream in 250 ml—with room for expansion as the market develops and new products are considered for long life treatment. In fact, one of our first assignments in October will be the processing and packaging of Sun Rype apple juice.

Other potential products are yogurt drinks, infant formula, whipping cream and flavoured milks. Export possibilities are actively being explored.

But this is only half the operation at the new Abbotsford plant. The other is the brand new processing equipment for Cheddar Cheese. The emphasis on Cheddar will enable the Association to lessen its reliance on butter, powder and evaporated milk and to slowly move into more productive markets. At some time in the future, we expect to distribute about 20 different cheese types from Abbotsford. This however, is another story and will be covered in future issues.

The need for this building at Abbotsford was immediate and it has taken only eight months to complete facilities which would ordinarily have taken several years. The energy and enthusiasm of the FVMPA Engineering Department, directing the contracting firm of Allan and Viner Ltd. has been responsible for this speedy progress.

Some of the engineering features are quite unique. The energy-efficient heating system provides direct gas-fired units mounted on the roof. All water leaving the plant will be monitored by amount, temperature and pH level and the flow of water is controlled by the addition of a cooling tower which permits re-cycling. At present, the office is on one storey but designs have allowed for a second storey to be added at some future time.

It has been estimated that about 20 employees will be working in the UHT operation and once the cheese area is in full production, the new plant will probably employ about 45 to 50 people.

When the new facilities open, **Bob Craig**, Superintendent of the adjacent Pacific plant, will take overall responsibility for the new plant as well. His assistant, **Rick Nichols** will supervise the UHT operation in particular. **Harvey Hennings**, who recently completed a training course on UHT equipment in Scotland, as foreman will train employees in the new processing methods. The marketing and promotion of all long life products are managed from Burnaby by **George Hrennikoff**.



Bob Craig (r), superintendent at the new Abbotsford facilities and Rick Nichols, supervisor of the UHT operation.

promises. Ultra heat treatment is considered by many to be the process of the future for many perishable fluid products because of the substantial energy savings involved. UHT milk will be treated as a grocery item requiring no refrigeration in the plant, in transit

What is U.H.T. treatment?

UHT treatment is a technique for preservation of food and beverages in which micro-organisms are killed by exposure to brief, intense heating (normally to temperatures in the range of 130-150°C).

UHT treatment is a continuing process which takes place in a closed system to prevent contamination of the product by exposure to airborne micro-organisms. The product passes through heating and cooling stages in quick succession. The container is formed, filled and sealed under aseptic conditions. At Abbotsford the method used is *direct heating* by injection of steam under pressure and cooling by expansion under

vacuum. (See graph).

UHT treatment renders the product completely sterile. The normal microbiological processes that cause spoilage cannot take place in a sterile product, which can therefore remain fresh for months or longer.

Pasteurization results in only partial inactivation of bacteria, and the preservative effect is therefore limited (to about one week in the case of milk).

UHT treatment has little if any effect on the flavour, nutritive value, consistency or other properties of the product. The exposure to heat (especially with the direct heating method) is so short that it does

not have time to cause chemical changes (cooking), or degradation of vitamins.

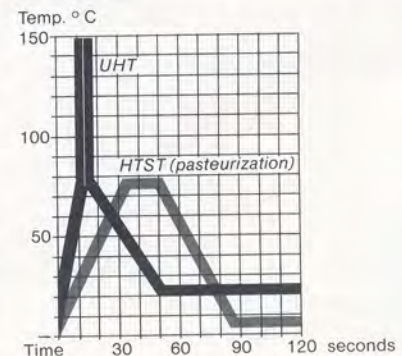

THE UHT process uses higher temperature, with the injection of steam, and a shorter time compared to regular high temperature short time (HTST) pasteurization.



Howie Stevenson (r) with programmer Pat Lysiuk.

Office co-ordinator

Howie Stevenson, Manager of Data Processing has been asked to assume the added responsibility of Office Co-ordinator at Burnaby. Howie will be involved in the non-technical areas of office staff activities, primarily dealing with interpersonal communications among staff members, the various departments and the Association.

Howie believes that a good working environment depends on healthy relationships between employees. He says, "I am happy to be asked to participate in this area of communications of management and staff."

To charity

The FVMPA has contributed toward the expansion of the Bevan Association's Special Opportunity Centre in Courtenay. **Ron Mottershead** presented the cheque to administrators of the centre for handicapped children.

Unknown artists?

Butter-Fat magazine is always on the look-out for different styles of art to illustrate a variety of subject matter. If interested, contact the Member Relations department, Burnaby.

PUBLISHED FOR THE INFORMATION OF THE EMPLOYEES OF THE FRASER VALLEY MILK PRODUCERS' ASSOCIATION, 6800 Lougheed Highway, Burnaby, B.C. Editor: Verlie Bousfield, Mailing Address P.O. Box 9100, Vancouver, B.C. V6B 4G4 Telephone: 420-6611

Eighties viewed with optimism

In his address at the recent Annual Meeting at Chilliwack, FVMPA President **Gordon Park** reaffirmed the basic principles of the Association and outlined goals for the eighties. He said, "We must use the FVMPA wisely, share in its rewards and responsibilities and then turn it over to the next generation better than we found it."

Mr. Park outlined three major areas of the Association to its members. "The first is the marketing of milk and dairy products in a manner seeking the highest return available from the market place," he said.

The second area dealt with the representation of B.C. dairymen in all levels of government through organizations that have the welfare of the dairy industry at heart. Thirdly, Mr. Park stressed member services, such as the Locals, publications and newly formed Insight and Young Cooperators programs, as invaluable in gaining direction from the membership through its active involvement.

Achievements

FVMPA General Manager **Neil Gray** reported on achievements that took place over the past year.

The improvement of Field Service programs to the members, under the direction of **Bob Irwin**, included the hiring of more fieldmen and assistance in analyzing the complete milking operation on farms. Special educational programs organized by **Tom Low**

enabled dairymen to learn more about their Association.

Greater efficiency in processing and packaging the larger volumes of milk being handled at Burnaby was achieved by adding new equipment and reorganizing entire production lines. This was carried out by production staff under **Grant Larkin**.

Accountability of people and product continued to give beneficial results. The accounting department under **Roy Moore** has been reorganized for more control systems and greater automation.

Heavy emphasis is still being placed by **Bill Hawes** and his staff on cutting distribution costs through better routing and fuel efficiency.

Mr. Gray credited the increase in per capita sales to the aggressive advertising, merchandising and sales programs under the direction of **Jack Aird**. He stressed the importance of diversifying products, with particular emphasis on the single portion fast food and institutional markets.

Mr. Gray credited the Engineering department under **Don McQueen's** direction, for the rapid progress of the U.H.T. and Cheddar plant at Abbotsford. He outlined future marketing plans for long life products and the expansion of the Cheddar and specialty cheese operation. He said, "Both product lines have an exciting future with many long term benefits to your membership."

Retail extends soap line

An addition to retail's range of products was made in April. Dishwasher detergent was introduced to complement the already popular B.C. 100 Laundry Soap.

The product, which is already in commercial use in B.C., has been offered to retail customers in an economical 7 pound bulk pail. Initial reaction from customers has been favourable as driver sales personnel have presented the product.

"The dish detergent addition is part of our aim to combine high quality products with the best possible service and convenience to our retail consumer; convenience including not having to carry heavy, bulky items home after shopping," says **Russ Webb**, Manager of Home Service Distribution.



Frank Wilkie, retail reliefman, discusses dishwasher detergent with Mrs. John Gray of Burnaby.

TV documentary, continued

linked together smoothly, CBC had previously taped some footage at the Burnaby plant. Here, **Dennis Haner** demonstrated some of the latest processing equipment on the production floor and **Gail Christy** gave a samp-

ling of our quality control tests and some new products which are being developed.

Tom Low later commented, "Although technical difficulties prevented the live segments to be shown live,

they went on the air exactly as taped along with all errors, sputterings and backs into the camera."

As a result, an entertaining and varied presentation explored all facets of dairy farming in an urban area.



Bob Switzer, (r), host of Sunday Magazine T.V. show, interviewed Tom Low on dairy antiques at the farm of FVMPA member Bob

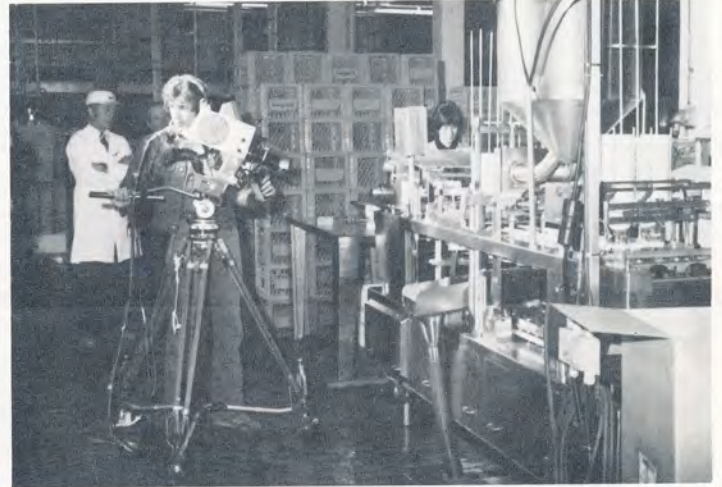

Robertson. Also on the program were film clips of the milk processing operation at Burnaby.

D'land drivers still misers

Once the big push of a contest is over, people often slip back into exactly the same routine as before. This is not true of the FVMPA's "fuel miser" drivers who again showed improvement in their gas utilization in 1979 over 1978.

Our drivers used 4.4% less fuel last year. The best results were attained by Ingles' Islanders of the Northwest district with 11.1% less fuel used.

Distribution manager **Bill Hawes** is proud of these achievements. He says,

"Our supervisors and driving staff are really working as a team in thinking up new ways to conserve motor fuel."

Saving gas usually means more thinking and organization, not more work. Some of the ways drivers can improve efficiency are: examining their driving habits, determining the shortest distances, "straight-lining" routes (which really means making deliveries in a circular route) and negotiating *acceptable* decreases in deliveries with their customers.



Fuel efficient milk delivery in Edinburgh, Scotland. The photo, provided by Doug Pilgrim, was taken by a friend on a visit last May.

Biggest breakfast on record

Remember about a year ago, we published the results of a weight loss contest between some of Burnaby's distribution staff? Well they're at it again, struggling to remove poundage accumulated over the winter. **Harry Dexter, Ralph Ruddy** and **Bill Morton** have a \$5 standing bet at each monthly weigh-in. Bill says so far he has lost 18 pounds, but Ralph personally feels that Bill must have led his pockets for the first weigh-in.

Ralph was one of several eyewitnesses who saw Bill consume the following breakfast one morning in the cafeteria:

- a triple order of sausages (6),
- a double order of eggs (4),

a double order of toast (4 slices), an almost full litre of Orange Juice and, two cups of coffee.

Stated the cafeteria staff, "There is no way one man will eat all that".

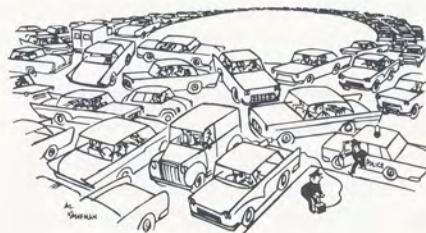

"Hold it, O'Leary, there must be a better way!"

Appointments

Ernie Brown has been appointed manager of the Armstrong Cheese plant at Armstrong. The announcement was made Feb. 1. The plant was previously managed by members of the **Adrian Schrauwen** family who started "Dutch Dairies" many years ago and sold the business to the FVMPA in 1977.

Ken Ueland has been appointed a Sales Representative in the lower mainland area. Ken has a proven sales record both in previous positions and as a retail driver-salesman for Dairyland.

Drivers Get Their Show on the Road



Ron Bush (l), John Chase, Jim Masterman, Tom O'Connor, and Rod Deakove put their act in gear at this year's Truck Rodeo. Also performing were Ed Kemp, Harry Willms, and Bernie Macdonald.

Emphasis Now on Milk Break

The Association produces several publications on a regular basis to communicate with various groups of people. In recent years attention has been focused on these magazines and newsletters to ensure that their defined objectives are being reached.

Butter-Fat magazine has undergone a major reevaluation in appearance and content to ensure that each issue holds relevant information for dairymen-owners of the F.V.M.P.A. as well as those involved in agro-business and the dairy industry.

Our efforts with **Butter-Fat** are showing positive results, as evidenced by the highly favourable response of subscribers and advertisers alike.

As design and production editor of **Butter-Fat**, Verlie Bousfield has been directly involved with the improvement, efficiency and overall impact of the magazine. Verlie has also continued to edit the staff newsletter.

Our objective for **Milk Break** is to expand the scope of reporting, publish on a monthly basis, and establish the editor's position as a full-time job. Verlie moves to added responsibilities with **Butter-Fat** and Richard Muller joins staff as the new editor of **Milk Break**. We hope the expanded newsletter will play a growing part in helping us understand and appreciate each other and our contributions to the Association.

The 27th Annual B.C. Truck Rodeo was billed as a big show, the news release promising "displays of trucks, trailers, automotive accessories, and much, much more".

I arrived shortly before the opening ceremonies Sunday afternoon, June 1, to see for myself. The site: the aged Boundary Bay Airport. The atmosphere: anything but old and tired, much more like a carnival, a summer fair in the country, a show that justified its advance billing.

Oddly, I had come to find out only if the show lived up to its promotion, but once convinced that indeed it did, I didn't leave. There was one reason I had come, and eight other reasons why I stayed.

So I spent the better part of a Sunday facing into a relentless wind, watching eight of F.V.M.P.A.'s drivers watch other drivers on the course, waiting for **their** show, their chance to compete.

Some waited, hands in pockets, backs braced solidly against the wind, eyes rivetted on the intricate course, now on this turn, now on that pile-on. Sometimes their attention would be diverted by the sights and sounds of the fairgrounds — a parachuting stunt team, a P.A. announcement for free Dairyland ice cream for the kids — but then it would return to the business at hand, studying the course's plot, mentally rehearsing for their parts.

While some stood, others paced, marking time by looking at the track displays, grabbing a couple of hot dogs, listening to the fireman's band. All the while, the loudspeaker blared out the contestant numbers in their event, "number thirty-six, and thirty-seven, please report to the starter".

And to the starter they went, all

*cont'd on page two
(see The Road Show)*

Off the Desk

It is not enough to merely say that **Milk Break** will now be more pages, more often.

Milk Break has opportunities for you as well as for me. Two-way communication is the natural advantage a newsletter enjoys over other one-way media such as film and television. As readers, collectively you can write the most interesting column each issue — the letters to the editor column. Your comments — complimentary or critical, lengthy or short — are welcomed always, as are any information or inquiries which you would like to share with your fellow employees.

There is no reason why my name should appear solely in the credits; I urge each of you to contribute in any way you like, whether as correspondents from the branch plants and depots, as photographers, or as cartoonists. If your talents don't fit into those areas but you are still interested, please contact me and we can discuss other areas. Believe me, editors can be a very resourceful bunch.

Charles Lamb once said that newspapers always excite curiosity although no one ever lays one down without a feeling of disappointment. As you read the following pages, you'll be determining whether Mr. Lamb's statement has any validity in the case of **Milk Break**. I await your decision.



"Start off by memorizing everyone's name," Payroll's Karen Michal advises gullible, new editor.

The Road Show cont'd from page one

eight F.V.M.P.A. drivers, competing in five different categories. In the trucks at last, the waiting was finally over, the show finally theirs.

Nobody said the show was going to be easy; in all classifications there were some very tough acts to follow. But the F.V.M.P.A. drivers performed admirably, two of them collecting official recognition for their efforts.

Ron Bush took third place honours in the Tandem classification, while **Ed Kemp** placed second over-all in the A Train event. In the Walk-In Van classification, **Jim Masterman** narrowly missed capturing honours, placing fourth.

They all wanted to do as well as they could; their anticipation and patience proved that. **Harry Willms** of Sardis, for example, waited for most of the afternoon to compete — contestant number 48 in a 49-man event.

Fraser McLean, Assistant Deputy Minister of Highways, might have been wearing a Dairyland hat, but those eight drivers were wearing a lot more for the Association.

Thanks for the show, fellas.



Tandem-Tandem driver Harry Willms here tandems with Terry Thrun, F.V.M.P.A.'s contestant in the Rodeo Queen pageant. Terry is one of four finalists vying for the crown.

Marketing in Style

Marketing Services, responding to slackening sales in **Swiss Style Yogurt** and **Vem**, have revitalized both product and promotion.

"Market testing indicated that the quality of our Swiss Style needed to be improved", noted Don Winton. Consequently, changes were made in the formulation of the product: the fruit content was improved and increased, the percentage of butterfat was changed from 1.75% to 2%, and the artificial colouring was eliminated. The result . . . a product with increased richness and flavour.

Furthermore, with the Vem brand sales levelling off, Marketing decided to discontinue Vem, which was available only in the 175 gram size, and include this convenient size in the Swiss Style line. This means that Swiss Style is now available in the 1 kg, 500 g, 175 g, and 125 g sizes. Explains Don, "It's given us a total family look. We can now merchandise and market Swiss Style as a unit."

To emphasize the changes, Dairyland

has embarked on an aggressive marketing campaign. Leading the way in the campaign is the Swiss Style trip for two to Switzerland contest, currently enjoying a high profile in supermarkets and groceries.

The contest provides the initial incentive to try our yogurt. It also coincides with our effort to convince those who haven't tried yogurt to try Dairyland's yogurt first. "Surprisingly, forty percent of the market place has not tried yogurt," commented Don. "Since the key motivating factor in buying yogurt is fruit, our radio, newspaper and outdoor billboard campaign have relied on the theme that the new Swiss Style yogurt contains more fruit."

Complementing the advertising is a series of in-store demonstrations designed to attract people to the product. The Swiss Style brand has a decided advantage in such a demonstration because it is already pre-stirred, pre-mixed and therefore, easier to introduce.

A Look at International Relations: F.V.M.P.A.'s Workshop



Diplomats take note: the spirit of international co-operation is alive and well in our Burnaby Workshop.

You are excused if you accidentally mistake the Workshop lunch break for a conference meeting. After all, it's only reasonable to assume that when a man from Italy, another from Germany, and two more from Scotland — one via New Zealand — get together, *something* important is being discussed.

Actually, what **Ben Comin, Klaus Tewes, Alex Brodie,** and **Ernie Rooney** talk about is indeed important, even though it isn't quite international news. These four men, offering a smorgasbord of talents and interests, are all newsmakers in their own right at F.V.M.P.A.

Ben Comin took his machine maintenance apprenticeship at the age of fifteen in his native Crocetta del Montello, Italy. While long in name, the town was short on opportunities, so Ben moved to Edmonton, Alberta. Probably "moved" is the wrong word; "journeyed" more aptly describes a trip that took twelve days by oceanliner and five more days by train.

With the idea of retracing his steps triggering thoughts of premature old age, Ben accepted work at the Canadian National Railroad. He spent the next nine months travelling across the prairies laying track on stubborn, new ground for a thankless ninety cents an hour.

Moving to Vancouver allowed Ben to employ his skills as a machinist. Twenty-three years later, Ben joined F.V.M.P.A. Contributing to the improvement of our production machinery, Ben has perfected an invention of his own here, a vacuum suction device that picks up all twenty pudding cups out of a tray and moves them into the sleeving machine for packaging. The old way? **Anne Marmont** and **Louise Materi** had to remove cups from the tray by hand four at a time. To Anne and Louise, Ben certainly has a way of making friends.

Klaus Tewes makes a lot of friends too, especially among Gasti machine operators. Manuals for Gasti are often written in German and Klaus, born and raised in Cuxhaven, West Germany, ensures that nothing is lost in the translation.



Klaus Tewes (l), Ben Comin, Ernie Rooney, and Alex Brodie.

If the manual doesn't explain things, a Gasti representative from Germany usually does, and Klaus is again pressed into service as the interpreter. The latest example of this double duty occurred recently when Klaus spent two weeks with Gasti's **Manfred Umlauf** overhauling the sensitive machine at the Burnaby plant.

Alex Brodie has also added expertise and a cosmopolitan touch to the Workshop. Born in Bridge of Weir, Scotland, Alex planned his life in March, 1967; that was the month he got married and then emigrated to Vancouver.

His ability to revive tired, old machines has been a great asset to F.V.M.P.A. In particular, Alex rescued our shop lathe from near-obsolescence, stripping down and rebuilding the machine from top to bottom. Alex didn't just develop a better lathe; he virtually built a new one.

Another member of the workshop is also no stranger to the task of machine improvement. In fact, **Ernie Rooney**, whose work experience reads like a travelogue, has spent most of his life shaking off the term

"stranger". Starting as an apprentice with a Glasgow shipbuilder, Ernie then worked as a marine engineer in Britain and New Zealand. After nine years in New Zealand, he moved to Ontario, followed seven years later by another move to B.C.

An F.V.M.P.A. employee for the past three years, Ernie seems to have finally beaten the travel bug, but don't show him a map; he might only be resting.

His experience in pneumatics and hydraulics qualifies Ernie for an important role at the plant — that of trouble shooter for new equipment. The young novelty wrapper and box former, for instance, experienced many early problems; it was Ernie's ability to add and replace valves and shuttles that allowed for a simpler, more efficient machine.

Hats off and a salute to Ernie, Alex, Klaus, and Ben, four men with diverse personal backgrounds who dismiss much of the protocol that usually exists between people of different nations and settle down to the business of maintaining our machines.



Ask Rick Redding what's cooking and he'll tell you . . . literally.

Rick, our route foreman relief in the Tanker Division at Sardis, is also a night school instructor of Chinese cooking at Fraser Valley College. Each

spring and fall, he teaches forty people how to prepare anything from egg rolls to specialty courses.

The inevitable questions: why cooking, first of all, and why Chinese cooking specifically? Explains Rick, "I developed an interest in cooking because I'm a picky eater. I decided that if I cooked it myself, at least I'd know what I was eating."

A number of evening cooking courses allowed Rick to indeed have it his way. Four years ago, one such course was in Chinese cooking. When the instructor decided he no longer had time for the course, he asked Rick to take over. Since then, Rick has spent two nights a week for most of the year in front of a wok and a class.

"There's a great deal of interest in Chinese cooking in this area," he notes. "I've had sixteen-year-olds, seventy-year-olds, and even young Chinese girls in my classes. More and more men are also now taking the course.

Basically I try to teach all my students some of the regular dishes and also a few of the advanced ones as well."

One of the meals that Rick introduces to his students is dimsum, the traditional Chinese lunch. In a dimsum lunch, diners choose from up to fifty-two varieties of small dishes brought to the table on carts. There are no menus; prices vary according to the colour of the dishes and the type of bamboo steamers.

"It takes considerably more time than our conventional North American lunches, but it does allow a group of people to sample many different foods." Rick's favourite Chinese restaurant? He enjoys many, although he does suggest the Dynasty in Vancouver and the Happy Valley in Chilliwack. He'll have a chance to try many more spots this August as he, his wife Winda and daughter Christl drive all the way across Canada. After that, it's back to work . . . and a new set of courses.

Retirements

Milk Break reminds all employees that part of the Dairyland Employees Charitable Donation Fund's purpose is to provide gifts to retiring members of the fund. Membership information is available from **Jim Defries** or **Darryl Palmer** at the Burnaby plant. You can also call **Milk Break** for any other information on retirements or retirement-related activities.



Best wishes to **Larry Shaw**, recently retired after 27 years with the Engineering department. Trained as a machinist, Larry's inventive imagination and discerning mind were valuable attributes both in his early years as maintenance foreman and supervisor

and his later years as special projects engineer. Larry dedicated many hours to one of our most important projects — the installation of process plumbing in the mid sixties. Since 1976, Larry has contributed many ideas in the areas of milk salvage and energy conservation. He and his wife Laurette plan to enjoy a quiet retirement.



When F.V.M.P.A. purchased William Bailey's Burnaby dairy in 1931, **Ron Bailey** found himself working for a

co-op instead of his father. It was a big change but a lasting one for Ron; this month he retired from Dairyland after 49 years of service. During those years — the senior ones as a checker-loader — Ron collected many memories of the dairy. Today, those memories seem as enchanting as old photographs. He remembers, for example, how he started here, driving a horse and wagon in New Westminster. While recalling the past, Ron also looks forward to the future; on his last day of work he "threw the alarm clock in the garbage can" and resolved to spend more of his time attending CB Side-bander socials.

Milk break

Published monthly for the information of the employees of Fraser Valley Milk Producers' Association, 6800 Lougheed Highway, Burnaby, B.C.

Editor: Richard Muller,
P.O. Box 9100,
Vancouver, B.C. V6B 4G4
420-6611

INTERNATIONAL ASSOCIATION OF BUSINESS COMMUNICATORS
IN BRITISH COLUMBIA

Safe Driver Awards Night



Joe Macdonald [l] (11 yrs.), Ernie Train (11), Ike Reddecopp (11), Harvey Hewitt (11), Jim Boyd (11).



Des Vosper [l], Motor Vehicle Branch and Stan Bagot (28 yrs.).



Norm Jago [l] (13 yrs.) and Les Barnard (13).



The Sardis Tank Division is this year's winner of the General Manager's Trophy. Neil Gray [r] presents award to Gerald Adams.



Gordon Park, F.V.M.P.A. President, with Sheldon Forsyth [r] (22 yrs.) and Bill Woollett (24).

10-yr. awards went to Murray Apps [l], Rudy Zimmerman, Art Wagner, Harold Gross, Les Dewey, John McGregor, Bill Barnes, Lawrence Miller, Joe Rollheiser, Ian Harrison, Nick Wawryk.



Arnold Bellamy [l] (14 yrs.), Fred Yeomans (14), Jim Coleman (14), Bill Webster (14), Cliff Russell (12), Wade Schatz (12).



George McKillop [l] (20 yrs.), Bob Blackwell (18), George Bartels (20), Doug Miller (18), Pat Mangan (20), Marshall Currie (18), George Penner (20).



Des Vosper centers Al Germyn [l] (16 yrs.) and Fred Mattee (16).



19-yr. winners, Jack Scott [l], Joe Gray, Bill Cunningham, Malcolm Hayton, Ron Carmichael.



15-yr. winners, Roy Temple, Chuck Linder, Jim Gillis, Hank Reger, Joe LaHaise, Sheldon Nickel (Motor Vehicle Branch), and Bob Catterall.



21-yr. for Doug McLellan, Walter Olleck, and Berne Anderson.

Burnaby Team Doesn't Pass the Creamo

The coveted Creamo Cup will remain in the hands of Burnaby's hockey team for an unprecedented second consecutive year, following a 5-3 Burnaby win over the Dairyland Kamloops team on April 19.

Phil Valee, Jim Crawley, Darryl Palmer, Al Jobb, Ray Shellard, and Jim Miller shared in goals and assists for Burnaby. "No one has ever hung on to the cup two years in a row," mentioned an excited Jim Miller. What Jim failed to mention, of course, was that the Challenge Cup between Burnaby and Kamloops has only been around for two years. It's all in the way you say it, right Jim?

Predictably, the disappointed Kamloops team — host of this year's challenge — would rather talk about next year's game. Rick Taron, Ken Crockett, Brian Tailefer, John Chernoff, Ron Ratcliffe, and John Campbell (Cache Creek) can't wait for another grab at the Creamo Cup. Asked what single factor contributed to this year's result, Ron stated "weather." "Weather?," we asked incredulously. "Yes, our goalie was under the weather."

In all a winning weekend for both teams.

A Short Pitch for Golf

We remind Dairyland employees and suppliers that this year's annual Dairyland golf tournament tees off at 9:00 a.m. June 22 at the Tsawwassen Golf and Country Club. Jim Miller needs twenty dollars from each participant for green fees and dinner. To our large contingent of "occasional golfers": remember that you do not need to know your irons from your woods to have fun and win prizes. But keep in mind it is considered good sportsmanship to not pick up lost golf balls while they are still rolling.



Would You Like to Meet this Man in an Alley?

His name is John Bulger, and he has an alley chosen where he'd like to meet you. It's the Stry Co-op Bowling Alley, home of the Dairyland Mixed 10 Pin Bowling League early Monday nights from September to May. Currently planning to expand, the league is giving preference to Dairyland employees in its search for new members. If you are interested, act now; team lists must be finalized soon in order to prepare for the league opening in the fall. Call John at home at 254-7062. On second thought, call him Mr. Bulger.



They Really Feel Like Singing

*"When words leave off, music begins."
— Heinrich Heine*

It is difficult to capture in words what the music of Dairyland's Glee Club means to those people it reaches — the sick, the aged, and the handicapped. At the Glee Club's annual closing banquet May 19th, it was again evident that their music is above all meant to be felt. These folks really do feel like singing, and then singing some more. Their songs, a rich blend of classics and old favourites, are well-rehearsed and quick-moving, travelling as they do straight from their hearts to others.

1979/80 was another highly successful year for the Glee Club, conducted by Dairyland's Ken Wolfe. From October to May, the club

performed twenty-one variety show concerts in such places as the G.F. Strong Rehabilitation Centre, the Chilliwack Park Lodge, and the George Derby Hospital. Wherever they sang, the Glee Club always found a warm and highly-appreciative audience. The goodwill that the choir creates for Dairyland and the encouragement they provide to our local shut-ins remain present long after the last notes have been sung.

Dairyland looks forward to supporting the activities of the Glee Club for many more years to come. It is our privilege to be associated with those who so enjoy touching others with their music. If you would like to lend your voice to their efforts, talk to Ken Wolfe at the Burnaby plant or contact **Milk Break**.

skimmings

Promotions, appointments, congratulations, condolences, notes of interest, fillers . . . (fillers ? never!)

Promotion

Wendy Hurst moves to Calgary August 1st to assume the position of Sales Representative, Pacific Milk and Armstrong Cheese, for the Southern Calgary area. Promoted from the Wholesale order desk where she gained experience in the Pacific and Armstrong accounts, Wendy will be serving our clients in Calgary, Red Deer, Medicine Hat, and Lethbridge. As a native of Vancouver, she is looking forward to new surroundings and responsibilities.



Appointment

Tom Bastable is pleased to announce the appointment of **Paul Cook** to the position of Assistant Credit Manager, F.V.M.P.A. Paul will also assume supervisory responsibility in the Accounts Receivable department.

A former RCMP constable, he switched from patrolling streets to controlling accounts, gaining credit experience from various financial corporations, including Canadian Acceptance Corporation. Paul comes to F.V.M.P.A. after serving as a credit manager for Certified Brakes in Toronto.

Congratulations

Ed Hopko (Valley), **Jim Jenkins** (Burnaby), and **Joe Rollheiser** (Sardis) merit special mention this month for their sales efforts in our recent introduction of B.C. 100 Dishwasher Soap. Ed, Jim, and Joe achieved the highest individual totals,

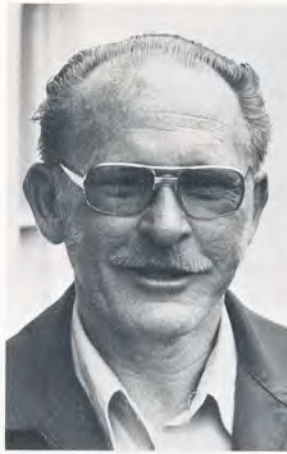

Joe Rollheiser

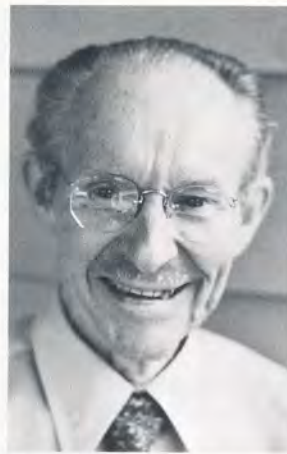

Jim Jenkins

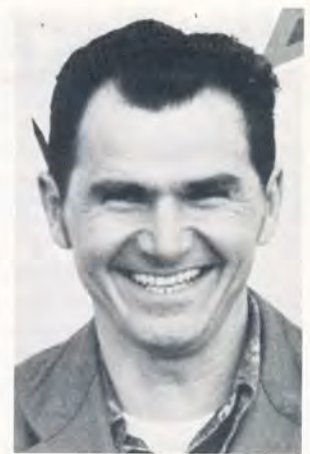

Ed Hopko

selling 160, 168, and 169 pails of soap respectively.

Remembering

Don Lewenden will be remembered by the many people in the dairy industry that he met during his life. Active in the industry since 1940, Don joined F.V.M.P.A.'s New Westminster depot in 1964 and the Home Service department in 1965. Well-liked by all, he retired as Assistant Supervisor, Home Services last June and then returned part-time to the Valley branch. The part-time work did not deter him from his interest in birds, hunting, and the outdoors. Don is survived by his wife Ruby, son Bernie and daughter Myrna.

Summer Training

Like an athlete, a professional driver needs to train in order to do his job effectively.

In any sport avoiding injuries depends on fitness, not just on luck. Similarly, in our driver safety program, drivers learn that accident-free driving is no accident; it demands training. Mental training can produce a safety-conscious driver, fit for the road.

The same kind of mental exercise can make safe drivers economical drivers as well. That is the reason behind the new Driver Training Program, developed specifically for Dairyland's drivers in the wholesale, retail and tanker departments.

Based on a recent distribution seminar in Detroit, the Driver Training Program will supply drivers with information on the mechanical operation and fuel performance of their vehicles. Adaptations have been made to the original program so that supervisors

and drivers can discuss group-related needs.

The Driver Training Program will begin this summer; now is the time to warm up to the idea.

Picnic Tick

Tick off Sunday, July 20th on your calendar, the date of F.V.M.P.A.'s Annual Staff Picnic. Rain or shine, the fun takes place at Blue Mountain Park in Coquitlam. Make sure your children are eligible for attendance prizes by registering them with **Harold Hughes**, Retail Supervisor.



Gasti Had Its Fill

The Gasti filler machine, which fills our milk, juice and yogurt cups and facilitates our service to B.C. hospitals, recently was in need of some care of its own.

Manfred Umlauf, a Gasti representative from Germany, and our own Victor Holt required two weeks, working around the demanding production schedule, to complete the necessary overhaul. Each night the production floor resembled an operating table for the Gasti examination, while each day the machine again had to be ready to supply 15,000 cups per hour.

Since its last overhaul, 4737 machine hours ago, the Gasti machine had filled over 71 million cups. It will now be another four or five years before the next house call is required.

Heading Out on Holidays?

At this time of year, every second Thursday takes on added importance; that pay cheque you receive helps pay for your upcoming holidays as well as your regular bills.

To inform you on one cost you fortunately won't have to worry about on vacation, the Association included with your last pay cheque a brochure detailing your Extended Health Benefits Plan (EHB). Take time to read and understand the plan; because of it, you are protected against a number of expenses not covered by your basic provincial medical plan.

In British Columbia our basic Medical Services Plan pays for doctor services, while EHB applies to expenses above and beyond those covered by the basic plan. These additional expenses are reimbursed at 80% inside B.C. and at 100% outside of B.C., after a \$25 deductible per person or family.

Become familiar with the types of costs that your EHB plan covers, both in B.C. and outside this province. You'll be pleasantly surprised by the plan's comprehensiveness. For example, did you know that inside the province EHB covers all prescription drugs after the basic deductible?

EHB has been in place for a number of years, but recently the Association was able to increase the liability limit from \$7,500 to \$25,000. Considering the escalating costs of out-of-province travel, particularly vacations, the new \$25,000 maximum makes the EHB plan far more contemporary. Keep in mind what that new limit means: all costs above and beyond those handled by the basic B.C. plan are covered up to \$25,000. Any claims made outside B.C. are covered at 100%.

The brochure refers to a life-time maximum payment of \$25,000. This in fact refers to a payment based on a particular accident or illness. Once a

full recovery has been made, the \$25,000 maximum is reinstated; and, of course, the \$25,000 applies per member of the family.

Remember, though, that in the event of any injury or illness, you need to pay any costs at that time and then make out an application to MSA upon your return home. In order to complete the form, you must have all your receipts for expenses. Application and any other information are available from the Payroll Department.

Still haven't read the brochure? Understandably, the chances of getting hurt or sick are probably the last things you want to think about before your holidays, but you need to be aware of how your plan works. Take a little test: how do you think your plan operates in this example?

Holiday breaks you don't need

Suppose, for instance, that during your holiday in Hawaii your family decided surfing looked like an easy sport to try. From the evidence above, Junior seems to be catching on, but the rest of you could hurt a lot more than just your pride.

Those broken bones would cost money to mend. As each of you gets washed ashore, waiting ambulances get you off the beach and on to hospital beds. A doctor examines you and concludes that surgery is necessary; you hope desperately that he works for free, but his five gold rings make you think otherwise.

Operation over, you wake up in your hospital room. The room service is fine; how about the rates? You become very sorry you asked.

In the case of your drugs and medicine, you may be taking them internally, but you have a nagging suspicion that you're really paying through the nose. Then, if all that lying in bed caused your old back injury to act up again, a chiropractor



would arrive to rid you of your pain and, yes, more of your money.

Even on the trip back home, you cannot escape the thought of your financial catastrophe; guess who is paying for those crutches and that cast?

All that needless worrying could have been avoided had you understood your EHB plan. If you had kept all your receipts, MSA would provide 100% reimbursement.

Naturally, we sincerely hope that you have a safe and healthy vacation. It is comforting to know, however, that should you fall off that surfboard, F.V.M.P.A.'s EHB plan will land you on your feet financially.

Producing Results

The Abbotsford plant had its first production-size run May 28, fourteen months ahead of a normal schedule. Usually, the sights and sounds of processing and packaging do not occur for twenty-six months, but step-by-step designing — keeping the design from out-distancing the job — allowed the

plant to be built in less than a year. "And at a \$1 million saving", gratuitously adds **Don McQueen**, Manager, Engineering Services.

Production possible, the job of ensuring that the product is sterile and saleable begins. "Product moves down one line", **Bob Irwin**, Laboratory

Manager, explains, "while packaging moves down another". And never the two shall meet, insists the Lab, without testing. The first production runs are currently undergoing quality assurance tests and product should be available on the market by the end of the month.

Ice Cream Production: Getting Ready and Being Ready

That favourite ice cream flavour of yours is actually the result of both FVMPA planning and flexibility. The production formula: every fifty gallons of ice cream mix equals one hundred gallons of ice cream. The missing factor? People.

Operators, such as **Nils Carlson**, **Larry Flynn** and **Gordon Triffit**, start work at 6:30 in the morning, preparing the freezer and the fillers for the day's production. The freezer, a large metal box fitted with six torpedo-like barrels, each one capable of holding 300 gallons, is rinsed and sterilized with cold water. Two fillers, the sweetheart filler for half-litre and one-litre containers and the Anderson for two-litre cartons, are checked and oiled with silicon.

Meanwhile, a formidable wall of plastic and cardboard is being built, pallet after pallet of packaging material to be used throughout the day. Ice cream ingredients, like walnuts and chocolate syrup, are pumped over from the vats and soon the freezer will begin churning out today's order of ice cream.

It's now 7:30 and the packagers — as many as twelve of them in the hectic summer months — have arrived. Some, like **Barb Fletcher** and **Iona Whyte**, may need to assist the operators during the initial production period, a time when the first heavy stream of ice cream is too soft and must be returned to the tanks to be reworked by the dasher.

The dasher, similar in design to an egg-beater, is a rotary element inside the freezer which whips the ingredients, keeping them creamy and smooth during the freezing process. (Incidentally, the dasher was invented by an American woman, Nancy Johnson, in 1846.)

Usually, the first flavour each day to reach the blades of the dasher is vanilla — 36,000 litres of it on this

particular day. Later, other darker flavours are also processed; they cannot be made earlier because their tastes would remain present in the tanks.

Flavours present specific problems to the operators and packagers like **Sybil Norris** and **Eileen Harrison**. The changeover time between flavours and brands is critical. Butterscotch ripple ice cream, for example, requires a ripple machine to feed the ripple into the filler, mixing it with the ice cream. Big Scoop flavours, like The Incredible Hulk (purple and green ice cream, of course) need to be packaged in the larger 2½ litre pails. And for all the 1886 flavours, packaged in paper rather than plastic, the machines need

to be adjusted slightly to compensate for the difference in packaging material.

Scheduling changeovers and production runs requires planning, but there are always occurrences that can't be anticipated. Flexibility here is the difference between continuity and chaos.

The Shrinkwrap machine, for instance, heat-sealing 6-8 cartons with a tight plastic wrap in a 400°F oven, may miss some of the packages. When that happens, packagers, like **Irene Pontious** and **Milka Mihaljevic**, stop the product from reaching the Shrinkwrap, moving from one position to the next, unloading the containers by hand from the conveyor belt. Since production doesn't stop, it is the packagers' ability to keep the belt clear that prevents bottlenecks.

Similarly, filling problems demand immediate action; if a machine should jam, pails need to be positioned to collect the overflow.

Producing ice cream, then, involves planning weeks ahead while dealing with problems in seconds. Next month, a look at how Dairyland makes its ice cream novelties.



Above, Sybil Norris handles the one litre packages for the Anderson filler. At right, Gordon Triffit feeds pails into another filler.



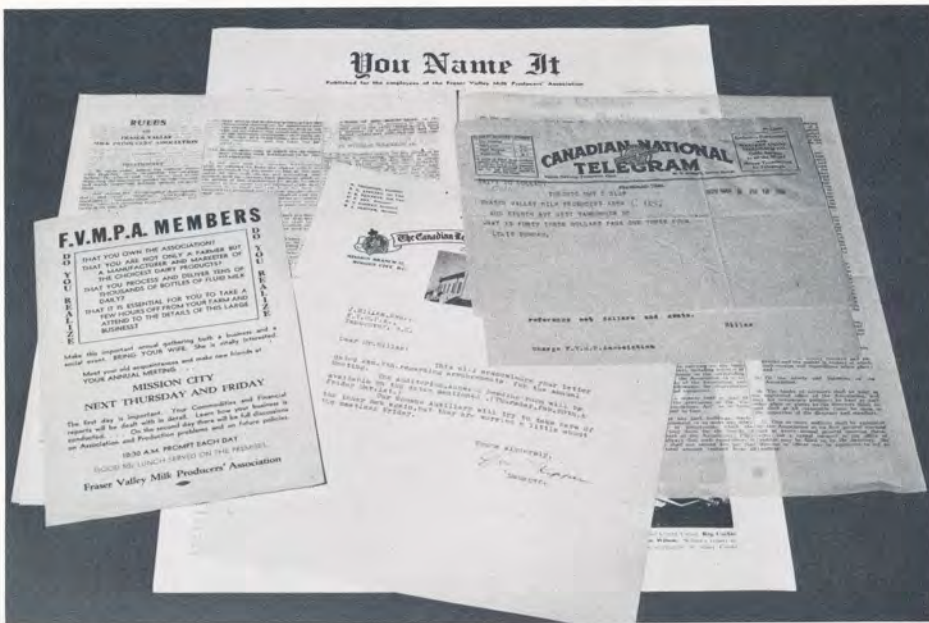

Examples of FVMPA material stored at the Archives, including the very first issue of *Milk Break*, predictably entitled *You Name It*.

Reading the Papers

I read about FVMPA in the papers — newspapers, note papers, minutes of annual meetings, and all the rest of the files housed — and permanently residing — in the City of Vancouver Archives.

The cataloguing of FVMPA's papers at the Archives was completed in the summer of 1976, a summer effort that spared many files from the fatality of spring office clean-up for all time. The Archives' objective being to log what businesses were like in earlier times in B.C., FVMPA's over sixty years of service to B.C. obviously attracted attention. Hastily-scratched notes as well as carefully-prepared reports were preserved, each telling a part of the FVMPA story.

And what a rich and colourful story it is. Indiscriminately, history decided who would be the famous and the not-so-famous characters in our story. A few, like Volker Vedder, left their names on the landscape, but all left future generations dedicated to dairy farming in the Lower Fraser Valley.

Newspaper clippings and other correspondences tell of how this valley became "the milkshed of the coast cities of New Westminster and Greater Vancouver" and later other areas of B.C. as well. By 1910, there were twenty-three creameries and one cheese factory in the province.

But the marketing system for the

products — distribution by a few milk dealers who stirred up competition and price wars — was described, politely, as "rather nondescript." Needing protection, farmers organized a marketing cooperative, the Fraser Valley Milk Producers' Association, granted its charter in 1913.

The majority of our files at the Archives document the growth of this fledgling Association into a strong, mature organization working to help its members meet the dairy needs of British Columbians. 159 volumes consisting of minutes, files, milk agreements, membership records, financial papers, published records, papers relating to the B.C. Royal Commission on Milk, scrapbooks, and photographs cover in words and pictures nearly seventy years of history. An indication of the size of our collection: I asked the archivist for only eleven selected volumes and minutes later she returned with them — on a loaded-down push cart that I wheeled, grunting, to a table.

Hours of leafing through those volumes revealed the diversity of people, products, and places interwoven in the FVMPA tapestry. The complete story makes for interesting reading and, should the Archives follow through on a plan to mount our history on a large portable display, the story will make for interesting viewing as well.

Thank You Note

The following is taken from customer Juanita Bouchard's letter to Dairyland.

"... I would like to commend the honesty of one of your employees, **Ernie Evans**.

"On my way to work I had dropped my wallet containing two cheques and cash that I needed for my rent. Mr. Evans delivers milk for me and found my wallet in the parking lot. All my papers, though, have my sister's address on them and I myself have an unlisted phone number, making it a problem for Mr. Evans to locate the owner of the wallet.

"However, on his own time he managed to accomplish this, coming back to my apartment the next evening with my wallet... I would just like you to be aware of his honesty as no doubt you already are; it is refreshing to see that there are still a few honest people around."

Supporting Role

Your newsletter depends on your support — active support, the kind that leads to stories, photographs, and notes of interest.

Milk Break's supporting cast this month includes Sardis' **Vivien Edwards**, who reported on some of the items appearing in *skimmings*, **Jim Byers**, who suggested the Cache Creek feature, and others who have recommended fellow employees for the *saycheese* profiles.

I invite everyone to play a part in the publication of **Milk Break**.



"These are the facts," Data Processing's Jim Burge tells attentive editor.

Long Distance from Cache Creek

The phone rings and branch manager **Harold Johnson** provides assistance, hooking up the distribution lines of our Cache Creek branch, moving FVMPA people and products throughout the area.

The Cache Creek branch is the centre point of a grid system that stretches 154 miles from north to south, about 70 miles west to east. Drivers **Gary Lawrence, Sid Koponyas, Jim Thompson, John Campbell, and Randy Steves** connect points as far north as Lonebutte outside 100 Mile House and as far south as Boston Bar. Warehouseman **Andrew Pemberton-Piggott** and office clerk **Margaret Jordan** monitor the network of inventories and accounts.

Describing the Cache Creek branch as a communications web underscores the reason for the success of the operation: the ability to reach customers in all directions. Whether west to Lillooet or east to Savona, the contact between FVMPA representative and customer is always direct.

That direct contact pays off; as the southernmost mainland depot to distribute a full line of frozen foods to stores and restaurants, Cache Creek increased its frozen food volume over 20% for the first three months of 1980 compared to the same period last year. Coupled with the potential market in the nearby Highland Valley, site of the 720-men Lornex and Bethlehem mining camps, the need for expansion

became evident. The four trucks and one special delivery van were restricted in use by a dock which only allowed unloading from the back. A 425-square foot storage facility was also overworked.

The enlargement added a new loading dock and a low temperature refrigerated storage, allowing for the Clark Reefer Lines trailer to be unloaded from the back and side at the same time and more than doubling storage space to a new maximum of 875 square feet.

The new freezer storage unit is a story in itself; it is a series of panels fitted together in the shape of a box, filling up the room but not contiguous to the room. This means that the entire unit can be dismantled and rebuilt in another location, should a larger room become necessary. The old freezers **were** actual rooms — the walls insulated with styrofoam — but when the room had outlived its usefulness, so had the freezer system.

The expansion will help the depot cover the surrounding ranch area like the rim of a cowboy hat, providing twice-weekly service to towns as far as eighty miles away. Harold started the



Margaret Jordan and Harold Johnson at work in our Cache Creek branch.

branch in 1969 with only one truck, but now the eight FVMPA employees, all from the neighbouring area and active in the community, are continuing to add new places to the branch directory and new customers to the listings.

Off the Bovine

Ralph Ruddy passes along this automation expert's description of the cow.

A cow is a completely automated milk-manufacturing machine. It is encased in untanned leather and mounted on four verticle, movable supports, one at each corner.

The front end of the machine, or input, contains the cutting and grinding mechanism, utilizing a unique feedback device. Here also are the headlights, the air inlet and exhaust, a bumper and a foghorn. At the rear, the machine carries the milk-dispensing equipment as well as a built-in flyswatter and insect repeller.

The central portion houses a hydrochemical-conversion unit. Briefly, this consists of four fermentation and storage tanks connected in series by an intricate network of flexible plumbing. This assembly also contains the central heating plant complete with automatic temperature controls, pumping station, and main ventilating system. The waste disposal apparatus is located to the rear of this central section. Cows are available, fully assembled, in an assortment of sizes and colours. Production output ranges from two to 20 tons of milk per year.

In brief, the main external visible features of the cow are: two lookers, two hookers, four stander-uppers, four hanger-downers and a swishy-wishy. There is a similar machine known as a bull. It gives no milk but has other uses.

Editor's Note — One question: where do you go for parts?



Gary Lawrence loads product.

Dialogue on

Dairy- Maid



The two castaways had seen many packages wash ashore on their lonely island, but never one quite like the unopened, laminated package, no bigger than a box of crackers, now lying face down in the hot sand.

Excited eyes scanned the package and attached note, "It's something called Dairymaid, and here's an outline of how Dairyland is going to market it."

His companion pulled himself away from the thin slice of shade cast by the sun-bent tree. "Dairymaid? Mmm, so that's how they're selling milk these days."

"No, not really," explained the discoverer, his eyes busily moving across the outline pages. "Dairymaid won't cut into fresh milk sales, but will create new markets."

"Such as?" The bitter heat had soured him over the years.

"Well, since Dairymaid doesn't need refrigeration for up to four months, it's a perfect pantry shelf item for those consumers who run out of milk on a regular basis. Marketing research showed that people running out of milk really wanted 'milk for emergencies.'"

"We run short of milk, now that we're down to one coconut tree."

"The advertisements refer to Dairymaid as the 'emergency milk.' But it's not just for emergencies."

"I don't get it." The concept was still as blurry to him as the heat waves on the horizon.

"Well, because of Dairymaid, fresh milk can now be enjoyed by campers, boaters, mining, logging and fishing camps, and those customers in non-service areas."

"Does that include castaways?"

"Of course not. I wish you'd stop being so sardonic; after all, this is something very new and exciting for

British Columbia and the FVMPA. Distributors and stores have to be informed on the features of the product through trade information and consumers need to be educated and motivated through merchandising activities."

"I'd like to know if it's really even fresh milk."

"That's exactly the kind of question the public relations program will answer. Consumers will learn that it **is** fresh milk and has no preservatives, through a series of booklets, sampling programs, in-store demonstrations, and recipe information leaflets.

"Get that recipe leaflet. It's your year to cook, remember."

"I could really use this Dairymaid, in either the one litre or 250 millilitre size. The one litre size holds about four single servings of milk and is smaller than a large family package."

"Floats easier too," noted the companion, watching the little waves carry the package back and forth over the shore.

"Look, here's a copy of their newspaper advertisement; FVMPA has also purchased fourteen weeks of television advertising and ten weeks of radio, both of which began July 14."

"Is it July already?"

"This is only just the beginning of Dairymaid's potential. Future plans include marketing a light cream under the Dairymaid label as well as

developing Dairymaid whipping cream, yogurt, and flavoured drinks such as raspberry and banana."

"Good, I'm getting tired of your 'banana surprise.'"

"Nobody forced you to eat it. Anyway, all these products will naturally also be sold in these sterilized packages, requiring no refrigeration for up to four months. Hopefully, in a year or two, the name Dairymaid will refer to a complete, non-refrigerated dairy product line."

"Hopefully, in a year or two, we'll get a mailing address." He smiled at last. Suddenly, because of Dairymaid, the dry, old island didn't seem so bad after all.

Milk break

Published monthly for the information of the employees of Fraser Valley Milk Producers' Association, 6800 Loughheed Highway, Burnaby, B.C.

Editor: Richard Muller,
P.O. Box 9100,
Vancouver, B.C. V6B 4G4
420-6611



INTERNATIONAL ASSOCIATION OF BUSINESS COMMUNICATORS
IN BRITISH COLUMBIA

Sticks and Students

Joe Jessup, Burnaby Stock Room, receives so many requests for popsicle sticks that he's seldom sure what people are doing with them all.

So when Joe Paine, a teacher at Dr. Charles Best Junior Secondary in Coquitlam, asked Joe to supply 10,000 popsicle sticks, Joe raised his eyebrows, obliged, and did little more than wonder at the absurdity of it all. "All in the name of public relations," he rationalized.

Months later, Joe found placed on his desk a bridge made entirely of popsicle sticks with an accompanying note, "Thank you for getting us into what turned out to be a first-rate engineering project." It was signed Joe Paine.

Our Joe then immediately phoned **Milk Break**. "Please get this bridge off my desk" was the intention. "See if you can take this bridge and get a story out of it" was the actual suggestion.

I contacted Joe Paine and discovered that the bridge was one of eighteen built as applied science projects by two Grade 9 classes. Joe's brother-in-law — an engineer — had done a first-year engineering project on bridges, so Joe rewrote the project to a Grade 9 level and announced the assignment: design a bridge as strong as possible, using only one small bottle of glue and a maximum 350 popsicle sticks. All the bridges had to meet certain dimensions and, when completed, would be tested for strength.

Every one of the 10,000 Dairyland popsicle sticks was used; in fact, when it came time to surface the deck, wooden splints had to be used instead.

The best bridge, built by Brett Chedrick, Roy Supeene, and Brock Simmons, and withstanding 16,000 grams with only two millimetres of sag, was then placed on Joe's desk at Dairyland.



Collecting Interest

Roy Stark is a collector of interest, a man who has accumulated a treasure chest of stories and anecdotes from the world of collecting.

It is the nature of this world of collecting to resist any attempt at definition. In this world, all men are created exceptions and Roy Stark, the receiving foreman at Sardis, is certainly one of a kind.

He started by collecting birds' eggs as a child, but he decided, much to the relief of concerned mother birds, that there were other ideas worth hatching. When he began work straight out of high school in 1951 in the butter room at Sardis, his knack for knick-knacks had netted him such items as Indian baskets, kerosene lamps, and coins.

"I've always asked myself two questions when considering to buy," comments Roy. "First, is it something I like? You have to buy what you like, but at the same time you have to remain emotionally detached from the object; never treat it as more than an investment."

"Head over heart, then," I interjected, perhaps not originally, but intelligently at least, I thought. "Yes," said Roy's mouth. "Another amateur," said Roy's eyes.

"The second question," he continued, "is whether or not the item is a good buy financially. That's not something you learn overnight. It takes a lot of reading, and visits to collections, museums, and auctions."

The knowledge you pick up over the years could fill a book with trivia. "For

example," he suggested, "did you know that gold gives off a certain oxide that brass doesn't and that a reliable test for pearls is to see if they feel cold on your teeth?"

No, I admitted, I did not, relegating myself to the ranks of the uninformed.

"You get better at it all the time," Roy reassured me, "and everyone naturally develops an area of expertise. With local Indian art, for instance, you get to the point where you can even determine who made it and what area it was made in — that's how specialized you can become."

Even with specialists, collecting is still much more an art than a science. "Collecting makes you a student of human nature and human nature can be very unpredictable," states Roy. "That's why the same item will never sell at two auctions for the same price. People are as much bidding with each other — feeling each other out — as they are bidding for the object. It becomes, then, harder to buy a good item than to sell it."

Roy then played the part of the mentor; if you want to get started in collecting, advertise in a local paper, and that way you stay out of the system, avoiding collecting other people's cast-offs. Eventually, you'll develop a reputation as a collector of a certain item or a certain type of object.

We ended the conversation, I the wiser — and maybe someday the richer — for it.

skimmings

News that's fit to print, but doesn't fit anywhere else.

Welcome Back

Greg Osborne returns here after graduating with an MBA from the University of Western Ontario. Greg completed a special project last summer for the FVMPA and held other dairy related positions prior to his work here. He will be assisting **Ernie Brown**, plant manager at Armstrong.

Goodbye

Fred Maynard is leaving the Sardis Butter Room Department to take life a little easier on his small farm in Armstrong. An employee of the Sardis plant since 1957, Fred is planning to raise a few beef cattle and enjoy his new lifestyle with his wife Charlotte.

Good Progress

Doris Holmes, Office Supervisor at Sardis, underwent heart surgery in late May. Although the operation was a major one, Doris recovered quickly, even managing to visit the office on June 6th. Continue the good progress, Doris!

Wine and Cheese

Staff and Welfare Fund organizers wish to remind everyone of the Wine and Cheese Party Saturday night, August 16th. The party, to be held on the new patio and in the cafeteria, is free, so keep that summer evening free, too.

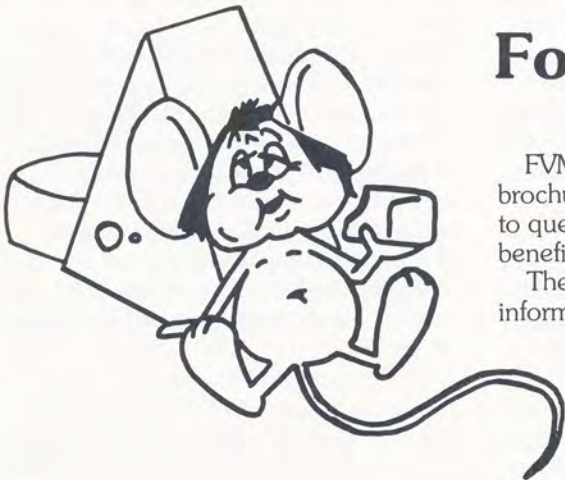

Condolences

Roy Elford, Burnaby checker, died suddenly in May. A Dairyland employee since 1965, Roy transferred from the Production Department to the Fluid Checking Department in 1969. He is survived by one son and two daughters living in the Lower Mainland and his parents in Parksville.

Never on a Sunday

By 1890, ice cream sodas were already a favourite drink in Evanston, Illinois, but there was a town law that banned "stimulating beverages" on Sundays, the Sabbath, and that included the fizzy ice cream sodas. So on Sundays, a drugstore operator began to serve ice cream with syrup on it, instead of sodas. He purposely misspelled it 'sundae' so as not to get any lawmakers or concerned citizens upset.

Oops

My apologies to **Ed Ydenberg**, who was right in the middle of last issue's picture of the 15-year safe drivers, but nowhere to be found in the credits.

Etc., Etc.

Sam Fogel, a consultant to the FVMPA and to the B.C. Dairy Foundation, has been appointed to the Board of Directors of the International Society for General Semantics, which publishes a journal called **Etc.** The former FVMPA advertising manager will represent Western Canada on the Board and attend this year's international conference in Toronto.

Shot Count

Wayne Rogers' two-under par 62 was the winning score in this year's Dairyland Golf Tournament. The Burnaby night checker was followed by ex-B.C. Lion Ted Gerela, now a Dairyland supplier.

Employee low-net honours went to **Al Sawatsky**, Sardis Retail Sales. A retired Valley sales driver, **Wilf Balderston**, and a Burnaby retail driver, **Pat Fiddler**, won the closest-to-the pin contest, while **Wayne Rogers** and **Dave Hudson** from the Valley branch registered the longest drives.



Bill Mehlen, Ralph Ruddy and Kelly Ingram take up cart racing.



Ruth Perry teaches Jim Miller how to print his score.

For Your Benefit

FVMPA is developing a benefits brochure which will provide answers to questions regarding the staff benefits package.

The brochure will be a handy, informative reference for both current

and new staff alike, outlining the type and the extent of coverage available. Hopefully, the pamphlet will be distributed this fall; until then direct your questions to your supervisors or the Payroll Department.

When the benefits brochure becomes available, **Milk Break** will devote regular attention to specifics in the package, giving examples of how and when parts of the plan work.

Retirements

Milk Break reminds all employees that part of the Dairyland Employees Charitable Donation Fund's purpose is to provide gifts to retiring members of the fund. Membership information is available from **Jim Defries** or **Darryl Palmer** at the Burnaby plant. You can also call **Milk Break** for any other information on retirements or retirement-related activities.

A nickname can be a sign of friendship, an indication that the person deserves something a little extra for that little extra he himself gives. When specials driver **Ken Howatt** was tagged with the nickname "Seal Cap" during the introduction of sanitary caps on milk bottles years ago, it was meant with good fun and good feelings. Clearly, good feelings are something Ken has always managed to cultivate during his twenty-six years at FVMPA.

Starting on a small retail route, Ken can remember using ice bags on the old trucks; today he probably voluntarily replaces more empty milk containers in the staff cafeteria than he used to deliver. Good luck to Ken and his wife Helen on their well-earned retirement.



From nicknames to middle names... FVMPA is losing both a longtime driver and a bit of history in the person of **Ernie Rees A'Beckett Evans**. A descendant of Thomas A'Beckett, the Archbishop in question in Henry II's notorious cry, "Who will rid me of this priest," Ernie leaves the Association after forty years of service as a relief driver and a route foreman.

They're forty years that Ernie doesn't regret; for many years he even delivered milk on Christmas Day but always came home with boxes of chocolates and the old 'flat fifties' — cigarettes sold in flat cans — from his appreciative customers.

One thing he can't remember is slowing down — highly unlikely with five children and one set of twins — and Ernie and his wife Hazel plan to stay active, breeding exhibition rabbits and budgies.



Sheldon Forsyth's active life necessitated an early retirement; there wasn't enough time for all the things he wanted to do, like fishing, golfing, and renovating his house in Oliver.

Now living in Oliver with his wife Reba, he started in 1957 as the Association's first farm pick-up driver (Keith Miller started the same day but humbly concedes the distinction to Sheldon). The introduction of farm pick-up by tankers to replace cans was a major change for farmers. Today, Sheldon meets men and women on the farms who were only babies when he started his visits. While that might make him feel old, he certainly isn't

acting old; best wishes for all your plans.



Fred Matte's participation in the dairy industry goes back to 1946 and a plant known as the Creamland Dairies in Vancouver. A retail driver salesman ever since, Fred moved from Jersey Farms to FVMPA in the 1970 amalgamation, finally getting his opportunity to drive those FVMPA Mercury trucks he had always admired.

"I found the Association very different than the Eastern-based dairies," he comments. Born and raised in this area — he used to ride the Inter-Urban electric trains between New Westminster and Vancouver — Fred is especially proud to have worked for a B.C. company. He is writing his real estate license exam in September, hoping to ply his route salesman skills to pay for some extra vacations.



sportscoops

Something different this month; a look at the recreational activities open to all FVMMPA employees. Instead of reporting the scores of the games FVMMPA people play, we're giving you a chance to get in on the action yourself. Get out of that lumpy armchair and

that lumpy body and join a team, or even a couple of teams.

Your fellow employees who organize all these activities need your pull — muscle pull, that is, or even a really good cramp that you wouldn't mind incurring for the sake of your team.

You may find that the activity you are interested in doesn't take place presently in your area or branch. In that case, just drop a line or a note to **Milk**

Break. I'll then play matchmaker and help those people in the various areas make some matches against each other. (You were thinking I meant something else?)

So grab a pen, some paper, and the phone, and become a part of the wide world of FVMMPA sports. To those that join goes the thrill of victory, to those that don't, the agony of default.

Hockey night at FVMMPA is actually hockey morning for most of our groups. Rick Moore (585-7061) and Ron Flash (987-8871) organize a group that plays year-round Monday nights from 5:15 - 6:45, but the other two groups play earlier — much earlier in one case.

Brian Quinn (434-1491) and the night checkers invite anyone who can get up in time to join them from 5:00 - 6:30 one morning a week throughout the winter at Four-Rinks. They start dropping the puck in September.

Ron Ratcliffe books ice-time in Kamloops, while Jim Miller of Creamo Cup fame (or infamy?) runs a league that is not sponsored by FVMMPA and is made up partly of outside businessmen. You can, though, give him a call at local 270 about the possibility of joining as a spare player.



Bowl 'em over, either in 5-pin or 10-pin. The 5-pin league begins in September, so call Darryl Palmer at 939-4264 as soon as possible. The 10-pin league, also starting in September and running weekly early Monday nights until May, is looking for more Dairyland bowlers. John Bulger at 254-7062 is the person to call.

Allright, so dancing isn't a sport, but the annual dance is certainly one sporting good time. This year's company dance, organized by Staff and Welfare, is scheduled for November 20. Darryl

Palmer will keep us informed on the details.



The call 'fore' is bellowed just one day a year by FVMMPA employees as a group, but if you have been missing your annual chance to take to the fairways (and the rough and the bush and the sand traps ...) make a note to contact Jim Miller at local 270. It's a once-a-year tournament, but Jim plans well in advance for each event.



If you don't hit it off with those little golf balls, you can always try hitting something bigger, like a softball. Dairyland has a team in the North Delta Senior Men's Fastball league; the 22-game season runs from May 1 to the end of August.

As of mid-July, the team's record is 6-7-1, good for third place in their division. Three Dairylanders direct the team: manager Dennis Arychuk (461-5372) and coaches John Niemi (939-2891) and Steve Hallock. Each January, they rent a gym and invite new players to join the practises.

Every February there is a Dairyland curling bonspiel held in Chilliwack. Last year, twenty-four rinks from our plants and many of our branches participated in four-end games. The annual event also includes a dinner and dance. Call Jim Jones at the Burnaby Stockroom (local 293) for more information.



Good news: there were over forty teams in last year's Corporate Cup. Bad news: FVMMPA wasn't one of them. Contact **Milk Break** if you're interested in such events as the "Superstars" Obstacle course and the Bureaucratic Shuffle. I am personally pushing for an event called "That's Not My Jog, Man" in which a pair of running shoes is passed quickly from one department to the next.

Tennis, anyone? I would like to hear from you if you'd like to play tennis indoors throughout the fall. Delta's Airport Inn has courts and changing rooms available from 2:15 - 6:00; courts could be booked for Fridays so that those who have every other Friday off could use the earlier time and those that work 5-day weeks the later time.

Also, racquetball tournaments can be arranged at Super Court in Richmond. Whatever your level, please call me.



You may have to be a football hero to get along with the beautiful girls, but you don't have to be a hero to join the anything-but-beautiful guys who play touch football for FVMMPA in the B.C. Amateur Football Association's fall recreation league. Games take place on Sundays; Les Frederick (588-3914) and Kent Lillie (943-2619) would like to have you on the roster, especially if you're over 6'4" and eat with a shovel.

New Plant Premieres in Abbotsford

Long-range planning does not deal with future decisions, but with the future of present decisions.

Peter Drucker

Fifteen months ago, FVMPA decided to pioneer the idea of non-refrigerated milk in British Columbia. On Friday, July 25th, at the official opening of the new Abbotsford production facility, the future of that decision began.

It was an opening marking three inceptions — a new concept for British Columbia, a new product for the Association, and a new plant in Abbotsford — and it was afforded all the attention that a debut of this scope and stature deserves.

Provincial Agriculture Minister Jim Hewitt, Abbotsford Mayor George Ferguson, and Matsqui Mayor Harry DeJong played parts in the impressive opening celebrations. In all, about one hundred and seventy guests attended the afternoon event, highlighted by a



Plant opening afforded reporter the opportunity to question George Hrennikoff, U.H.T. Marketing Manager.



Agriculture Minister Jim Hewitt cuts ribbon outside the tanker bay to mark opening of new plant. Looking on, from left to right, are Abbotsford Mayor George Ferguson, general contractor Randolph Allan, General Manager Neil Gray, President Gordon Park, Matsqui Mayor Harry Dejong, and Don McQueen, Manager Engineering Services.

detailed but informal plant tour and a ribbon-cutting ceremony.

Many of those in attendance saluted the Association's decision. Agriculture Minister Hewitt spoke of FVMPA as a leader in the race for new markets and new ventures, while others reiterated what market research had previously confirmed — ultra-high temperature (U.H.T.) milk was an idea whose time had come.

Indeed, the decision to open a new production facility has been a timely one. Another article in this issue indicates the short-term success of the U.H.T. milk Dairy-Maid; the long-range prospects can only continue to be good.

The future looks bright — and so it should. After all, the Association decided that fifteen months ago.

Opening a Success

"The official opening of the new plant was very successful," remarked **Grant Larkin**, Production Manager. "Many of our visitors from the food buying and super market segments commented on the cleanliness and excellent appearance of the building and the equipment. Their good impression will help sell our product."

Larkin also complimented all the staff who worked hard during the start-up phase of the U.H.T. operation to ensure that the old and new plant alike were clean and tidy. "I thank you one and all on behalf of the General Manager, the President, and the Board of Directors for a job well done."

Roadside Check Marshals Respect for Garages

The recent roadside inspection program enforced by the Motor Vehicle Branch cast light on the success of our maintenance program while causing concern for many other commercial fleet operations.

In the Lower Mainland, checkpoints were established along major arterials and vehicles were stopped at random and subjected to fifteen to thirty minutes of testing. The final statistics spotlighted two facts: the number of vehicles with deficiencies consistently ran as high as 80 to 90% of the total number of vehicles inspected, but FVMPA's vehicles passed every inspection.

The success that our vehicles have enjoyed should be shared by many. Our comprehensive safety program, the product of the hard work and imagination of people like **Bill Hawes, Omer Tupper, and Doug Wilson**, is a thoughtful, convincing argument for the kind of driving that adds years to the dependable life of the vehicle.

But a long vehicle life means more than just good driving sense. It also means having the good sense to inspect and make decisions on vehicles long before a problem area takes shape, looking over that detail so easily overlooked. For their effort, the Association's maintenance team deserves to be commended. Bill McRoberts of the Motor Vehicle Branch applauds the work of the

Association and is one of many public and private spokespersons who have admired our program.

What of the program itself? Appropriately, the business of maintaining a close watch comes complete with its own set of watchwords: planned maintenance program, Fleet Service Drivers' Safety Reports, and **Mainstem**.

Mainstem, the registered name for a computer print-out system, provides a complete analysis of our fleet activity each month. Before this computer service was purchased in 1975, there was no way of improving cost control in the fleet or accurately budgeting for new equipment.

"Because of **Mainstem**," **Joe Robinson**, Fleet Supervisor, explains, "we know what to do with each particular vehicle. We can read off the total number of periods the vehicle has been on the program, the total dollars spent on maintenance, miles travelled — the list goes on. From all that information we decide whether to park the vehicle, or repair it before major engine problems occur."

That kind of decision-making facilitates a cost accounting system for the fleet; inventories show the age and condition of each vehicle, and those that need replacing are then phased out. As well, twice a year **Mainstem** provides a total life-cost analysis which forms the basis for new equipment



John Bowen huddles over equipment at the Burnaby garage.

recommendations.

What **Mainstem** has done for scheduled repairs, the Fleet Service Drivers' Safety Report program has done for 'semi-scheduled' repairs — work on problems first identified away from the plants. Any day that a driver feels there is a discrepancy in the function of his vehicle, he reports it on a service report card. An average of forty to fifty such cards are submitted each day, meaning forty to fifty fewer potential problems down the road.

In total there are forty-eight employees in Dairyland's garages, thirty-nine in Burnaby and the Valley and nine in Abbotsford and Sardis. Their work on such problems as the Drivers' Safety Report and **Mainstem** are appreciated all year round, but never more than when the roadside checks are in effect. Their efforts allow the Association's drivers to enter the checkpoints with a feeling of confidence and leave with a feeling of success.



Ralph Hughes

Retirements

The Courtenay branch sends notice of the retirement of checker-loader **Ralph Hughes**. A regular at that position since his start with FVMPA in



Ad Harrington

1974, Ralph plans to enjoy his free hours full-time now. He and his wife Teddy intend to do a little travelling and spend a lot more time on the golf

course.

Ad Harrington also retires this month. A janitor at night at the Burnaby plant since 1968, Ad has balanced off a quiet personal life against a colourful work history.

Born and raised in Vancouver, he moved to Burnaby Mountain in 1938 with his parents and still lives there today with his wife Margaret. "Now that my wife's retired from her job as a stenographer, she'd like to travel, but I'd prefer to stay at home."

Ad's work is a different story. He's worked in a theatre and also has the skills to run a printing press. Now that he's retired he'll also have more time for another of his skills — slide photography.

Depot Perserveres

"Through snow, sleet, hail, and over burnt bridges the milk must go on..."

That's the quote from Sharon Clow, wife of **Ray Clow**, a Dairyland driver at Vanderhoof. On July 23 fire broke out on the Nechako Bridge linking Vanderhoof with Fort St. James, causing extensive damage to the bridge and a lot of headaches to trucks and businesses.

Ray, **John Vander Ploeg**, and summer help **Ron Mason** hauled milk by dolly across from Fort St. James the day after the fire. "Our accounts were looked after," comments District Manager **Bill Ingles**. "Our staff did an excellent job. It's a long bridge to cross with a hand cart."

As well, both Vanderhoof depot trucks made one trip to Fort St. James, thirty-six miles north of Vanderhoof, via the Fraser Lake route. Normally a forty-minute trip, the drive this time took over two hours one way on a rocky logging road. Continues Bill, "I've commended Ray, John and Ron for doing the job while other dairy trucks sat idle until the following week."



Ray Clow (l) and Ron Mason bring milk across the bridge by dolly. Photo by Holly McNabb, *The Nechako Chronicle*.



At left, Barry Ingram stands beside the newly-invented 'pair of pants.' Innovators of this machine include Lorne Collie (l) and John Dick.



A Fitting Solution

They've called the machine the 'pair of pants.' Its inventors — the Sardis maintenance department — nicknamed it after its simple design, but this innovative solution to the noise and dust problems associated with bagging milk powder certainly didn't look simple two years ago.

Up until recently, the large twenty-five kilogram bags of milk powder were filled at the Sardis plant with a vibrating system that forced the powder out of a hopper and down towards the bags. Running the vibrator placed a great deal of strain on man and machine alike. The powder would clog up the machines, necessitating frequent maintenance by mechanics. As well, hour after hour of filling — as many as twenty-four hours a day at times — pushed the amount of noise and dust to high and uncomfortable levels.

Something had to be done. The noise and dust pollution were crippling employee morale but a counter-attack — **any** counter-attack — proved difficult to get off the ground. **Stan Lyon**, who took over the post of double charge hand two years ago, watched over a plan to install a guillotine-type shut-off valve, only to quickly conclude that the dust problem had worsened.

On to Plan B, followed shortly by Plan C, both of which failed to curtail the powder from running recklessly through the system. A project which had started out as a spare-time

assignment was beginning to look like a full-time annoyance.

Then **John Dick**, Sardis charge hand and welder, suggested that two streams of powder were better than one; if a double-bagging system could be developed so that half the flow of powder would fill one bag while the other half was temporarily held back, there would be no need for a vibrator or a hopper. The flow of powder would no longer be determined by a noisy, dusty vibrator but by two pipes — a 'pair of pants' — and a flapper inside that would angle the powder directly into only one pipe and down to one bag at a time.

Brian Padgett and **Brian Parkes** then developed an electronic shut-off device so that every time the weight of the powder bag tips the scale to the indicator, the flapper automatically changes sides, allowing the sifters to tie up one bag while the other bag starts being filled. A simple push of a button resets the scale and the whole problem-free procedure begins again.

Well, almost problem-free. A little more clearance is needed along the sides of the bag, and the filler on the other side of the machine is still causing all that old-fashioned dust and noise, so a similar 'pair of pants' needs to be installed there. But after all, the Sardis Maintenance Department is only human; they only put on their 'pants' one at a time.

Dairyland Shares in Squamish Days Celebration

It's the Sunday of the B.C. Day long weekend in Squamish, a day when the Dairyland trucks should be parked quietly at the depot and the employees off to their favourite fishing holes, enjoying the brief summer hiatus.

But at the depot the heavy hum of the refrigerators inside the trucks means that today is a holiday in name only. Since seven o'clock in the morning, one Dairyland truck has been downtown to supply a pancake breakfast. At the fairgrounds, there's another Dairyland truck with ice cream and drinks for a thirsty afternoon crowd. Everywhere there are people wearing Dairyland shirts. Today, FVMPA employees are showing what makes a co-operative work as they help their town celebrate the annual Squamish Days.

It is a festival truly with something for everyone. A weekend itinerary could include: pyjama shopping on Friday night, parade Sunday morning, and the annual logger sports show that afternoon. **Don Hobbs**, Branch Supervisor at Squamish, is Chairman of the Squamish Days Committee and

an enthusiastic supporter of the four-day event. "Squamish is a logging town and everyone turns out to celebrate Squamish Days."

There is a sense of pride that directs all the arrangements needed to stage an event of this size; it is a feeling that the employees at the Dairyland depot



Don Hobbs joins the crowd of spectators enjoying the Squamish Days' events.

share. It is their town, couched in an easy chair of green, there for friends and visitors to enjoy. Whether driving our trucks or outfitting both contestants and judges in our shirts, they were saying welcome to all, and welcome from Dairyland.

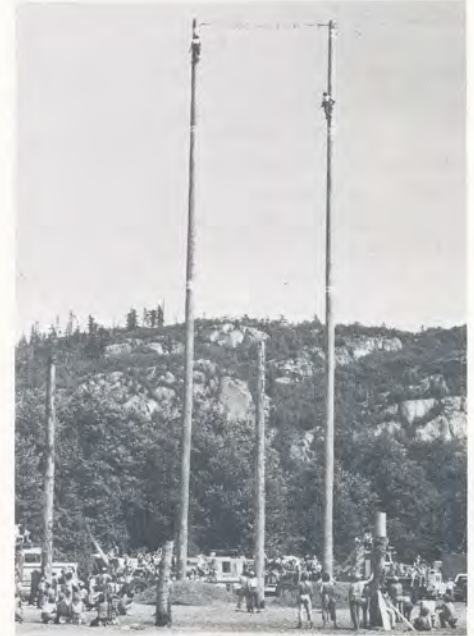

Dairy-Maid Sales "Overwhelming"

"Our supply just has not been able to keep pace with the demand," reports **George Hrennikoff**, Marketing Manager U.H.T. products, on Dairy-Maid's first month as a new product. "In a word, it's been overwhelming," he summarizes. "We started moving the product to the stores in late June and total sales for the month of July were 160,000 litres."

While that total exceeds initial predictions, Hrennikoff does not anticipate sales to continue at the present level. "Part of that large total sales figure must be attributed to what we call pipeline fill, which is simply a term used in the grocery industry to denote the different steps a product goes through before reaching the consumer. A store initially orders enough product to stock its warehouse, its stores, and its shelves.

"Also important in assessing first-month sales is the advertising and public relations programs that we've been running. We have received a lot of free publicity for Dairy-Maid, and

it's been the spur for a lot of consumers to buy the product out of curiosity. Many people have been buying the product and saying that this is the milk they saw advertised on television or heard about on the radio."

They've also been saying that they would like to know more about Dairy-Maid. "We've had many consumers request further information. The biggest single question, though, has been, 'When are you coming out with other Dairy-Maid products and sizes?' The 250-millilitre should be available in September. At that time we hope to be selling the chocolate flavour as well in both the 250-ml and one-litre sizes."

Hrennikoff did not end the discussion on the initial success of Dairy-Maid without congratulating our sales representatives for their enthusiasm during the introductory stage. "They've all done an excellent job in acquiring good locations for Dairy-Maid in the stores. They've worked hard to keep it as close to the

fresh milk section as possible."

Report cards, then, for the first month show top marks for everyone involved in the marketing and distribution of Dairy-Maid. But a special footnote should be saved for the lady at Woodward's Lansdowne Food Floor who saw the product, liked it, and bought it — nine bulk cases of it. George is right. "Overwhelming."

Milk break

Published monthly for the information of the employees of Fraser Valley Milk Producers' Association, 6800 Lougheed Highway, Burnaby, B.C.

Editor: Richard Muller,
P.O. Box 9100,
Vancouver, B.C. V6B 4G4
420-6611

INTERNATIONAL ASSOCIATION OF BUSINESS COMMUNICATORS
IN BRITISH COLUMBIA

Picnic 80



Question:

How much food does it take to feed about five hundred FVMPA employees and their families and friends at a picnic?



Calculation:

It was an ideal Sunday afternoon for a picnic, even though Saturday's grey sky had proved too stubborn for the sun. Add, then, the benign influence of a liberated sun to your calculation. Remember that there were many of those small but limitless energy sources, otherwise known as children, keeping up with their appetites. Also, add to every boy the two fudgsicles he took home in his pockets.



Answer:

Mel Hand drove two Dairyland trucks to the picnic and then drove back minus the following: 240 homogenized milk drinks, 1200 chocolate, 240 grape, 480 each of orange, lemonade, and raspberry, 42 dozen sundaes, and 100 dozen hot dogs.

Next Question:

When's the next picnic?



Leftover Note

"I attended the Dairyland Burnaby plant picnic on the 20th of July and found the pleasant surroundings and good company very relaxing. The children competed in the races, winning silver dollars, candy bars, and frisbees. They really enjoyed a very well-organized day.

"The highlight of our youngest daughter Jacqueline's day was still to

come; she was presented with an attendance prize of a ten-speed racer. She was delighted!

"We would like to thank the Association and the social club members for organizing a very good day."

Sincerely,

Brian Parkes (Sardis) and the Parkes family.

skimmings

This month's short stories that have risen to the top.

Remember When

The October issue of **Milk Break** will include four pages on the history of the FVMPA as you can remember it. There will be photographs of past employees, places, and events submitted by present employees as well as articles based on letters, notebooks, and the like that have been saved over the years.

If you have anything that brings back memories of your years at FVMPA, please write to or contact The Editor, **Milk Break**. Search your scrapbook and your memory for anything about the Association's past.

Special Thanks

A note of thanks to all of the employees at our new Abbotsford plant. They withstood the tide of media, government, and industry personnel who have toured the U.H.T. facility in the past few months. Our men behind the machines became an important part of the public relations effort to impress and inform all of our very interested audiences.



Good News

Aden Ford, the Abbotsford plant's chief engineer, is making a good recovery following heart surgery. **Rick Nickel** happily reports that Aden is doing really well and is recuperating at his home in Sardis.

Surprise!

July 10 was **Bonnie Kenal's** last day of work for a couple of weeks; it was to be a quiet, normal day before her holidays began. But her friends at work surprised her. When she left her desk in Wholesale Services and went for lunch, they were waiting there — for her wedding shower. "I was totally surprised," Bonnie, now Bonnie Kallin as of August 9th, recalls. "I want to say thanks to everyone for their time and effort."



A Lot to Learn

Gordon Aasen, Treasurer and Manager of the Dairy Industry Credit Union (D.I.C.U.), reminds all credit union members that their children may be eligible to receive bursaries or scholarships for their post-secondary education.

Applications for the financial assistance are available at the Credit Union. This assistance is offered annually through the Credit Union Foundation of British Columbia, the charitable arm of the credit union system in B.C.

At the same time, **Doug Wills** of the Maintenance Shop reports that daughter Christine, a previous recipient of a D.I.C.U. scholarship, received a gold medal for scholastic achievement at her graduation this year. Christine used a credit union scholarship three years ago to further her studies in the Faculty of Dentistry; today she is a dental hygienist.

Scholarships and bursaries — more good reasons to become a member of your credit union.

New Chairman

Bill Beagle, a driver for twenty-five years here until 1976, has been appointed the new Chairman of the Health Labour Relations Association (HLRA) of B.C.'s Board of Directors. Bill began as a retail driver in New Westminster in 1951 but retired early because of a back problem. He brings to his new position eighteen years of service as a trustee for the Surrey Memorial Hospital as well as experience in the Greater Vancouver Regional District and most recently in the HLRA as Vice-Chairman.

The HLRA is a board to which all of the acute care hospitals and some of the long care ones have given their certification for bargaining. These hospitals, in other words, are represented by the HLRA in all grievance and arbitration cases.

Congratulations on your new position, Bill.

Thanks for the Memories

Over fifty of Ken Howatt's friends at FVMPA met one lunch hour to wish Ken well on his retirement and to remember old times. Ken, the unsuspecting victim of a number of pranks over the years, joined in the laughter as stories were told one more time. Nice guys don't finish last, Ken. They just have to play along more.



It's Your Move

When you move to a new residence you need to make a second important move as well. Have your supervisor inform Payroll, or even phone the department yourself, regarding your change of address.

Updating your address guarantees that news in **Milk Break** and **Butter-Fat** reaches you while it is still news.

sportscoops

Sports Siblings

Walt Moran, Burnaby Workshop, is your typical proud father, but son Pat and daughter Kerry aren't your typical children on the playing field.

Eight-year-old Kerry plays soccer; nothing too unusual about that, except that she's the only girl on a boys' team. Only girl in the whole division, in fact. She played the whole twenty-game season and scored an unbelievable sixty-seven goals.

Eleven-year-old Pat is on a soccer team, too, a seventh-division team coached by Bob Spora that's won the league championship three years in a row. When he's not playing soccer, he's playing lacrosse for Peter Kent. Three years and three more championships. Pat played in this year's lacrosse championship and one-half hour later scored two goals in the Sun Soccer Tournament.

Sports sweeps, it seems, are becoming a family tradition.

B.C. Games

Derek Brennan, Burnaby Production, participated in this year's B.C. Games, held at Kelowna from August 14th to 17th. Derek competed in barebow archery — no sites, stabilizers, or assistance of any kind on the bow — in a division with six other archers. Congratulations, Derek, on placing fourth in your division.

Wanted: Baseball Manager

Okay, so you can't throw a good curve ball. But can you throw a good fit? Maybe you can't pound out that winning hit on the field. But can you pound out that new agreement at the meeting table? "What we're trying to say," explains **Randy Williamson**, "is that we need an administrative manager for the baseball team, someone who can act as the team's liaison with the league as well as perform duties as team treasurer and fundraiser. A secondary role as coaching assistant would also be expected." Interested? Phone Randy at local 211 or Dennis Arychuk at 461-5372.



saycheese

If you could live anywhere in the world, where would you live?

A challenging question for anyone, let alone **Peter Paget** of Data Processing whose thirty-nine foot sloop has allowed him to visit about sixty countries. Trying to answer the question produced a look defying anything but an equivocal description — first whimsical, thoughts in a fast interplay, then deliberative, thoughts ordered and collated.

"I don't think I could ever settle down in one spot," Peter begins. "In the Tropics, I love Cook Island in French Polynesia. In the Southern hemisphere, New Zealand is my favourite. In Europe, Austria." He pauses and then concludes, "It's all in what you want and I want it all. And you can't get it all in one place."

Peter first bought the boat in partnership with four other friends back in 1969. "We had no realistic idea of what we were getting into," he recalls. The partnership lasted a year and then the group disbanded in Fiji, agreeing to take turns sailing the boat by themselves.

Peter remained in Fiji for six months, witnessing the devastating attack of a hurricane on the grass huts of the surprisingly stoic villagers. When Peter's time with the boat elapsed, he kept moving, not returning to Vancouver until Christmas 1974 and by now a partner in a 100-acre farm back in New Zealand.

The travelling had stopped but the restless urge to travel had not, so when his turn for the boat came up again he anxiously took it and made an agreement with the partners to keep it; he's had the boat ever since.

Over the following years Peter must have felt like singing "If they could see me now" on a number of occasions; his newly-found sailing freedom has netted him experiences unequalled in the partnership.

There have been so many, many memorable stops. Like Bali. Three million people on a tiny island in Indonesia who display such a deep sensitivity that children cluster around and clutch at strangers. Or like Egmont Island. An Indian Ocean paradise so isolated that manta rays majestically swim by in the afternoon.

Nothing, though, paralleled Peter's experiences in the Red Sea area, its countries thick with oil and intrigue. Lawlessness, bribery, and a maze of religious taboos posed constant threats. "The officials are more dangerous than the pirates," he swears. He saw the painful birth of a new nation, Djibouti, its cafes and streets the victims of grenades, its poor the victims of a savage power struggle. He saw hay wagons probed for weapons and quick conversations tucked into dark corners during the Somali-Ethiopia war.

Peter even accidentally saw a military zone in Egypt — an accident that almost proved dangerous. His boat

continued on page 8

Ice Cream with Something Extra

A cool arbitrator between competing flavours. A soft cushion between crisp wafers. Ice cream, the marvelous utility food that goes into over sixty of Dairyland's novelty items.

If ice cream is in it, chances are that Dairyland's operators make it, using one of three novelty machines. **Mike Sawka**, **Bill Quayle**, and **John Goodwin** feed biscuits, chocolate chips, flavourings, and, of course, ice cream into the Lillypack 300, the sandwich machine, and the Vitaline.

Each machine churns out its own set of favourites. Troops of sundaes and drumsticks march out of the Lillypak, pass under the watchful eyes of packagers like **Lorraine Dronen**, are lined up into units and then sent down the conveyor line. The operation is slower with six packs, needing twice as much handling as do dozens.

On the sandwich machine, items are packaged either six, ten, or twenty-four novelties to a carton. The machine mainly produces Dairyland sandwich bars but it also makes products such as San Francisco Mint for other companies. With the mint product, chocolate chips are added to the ice cream via a fruit feeder. Bill Quayle tells the story in numbers; over two hundred and fifty pounds of chocolate chips and eighty boxes of wafers are used to make about forty thousand sandwiches on the average day. "That takes about five rolls of packaging paper," Bill computes.

Mike Sawka outlines the Vitaline process in steps rather than statistics. "Popsicles, creamsicles — anything on a stick, in fact — is made by the Vitaline machine," indicates Mike.

Metal molds — eight to a row — rotate on a cylinder that moves a new row underneath the filling hopper every few seconds. Once full, each row of molds is submerged and sent through a slushy yellow liquid called brine. The brine solution, about -32°C, forms a shallow pool along the bottom of the Vitaline machine and freezes the liquids in the molds.

A number of factors determine the next stage from here. Explains Mike, "If we're making creamsicles, we need to use suction tubes to empty the inside of the mold. This has to be done when the outside layer of the mold is frozen but the inside is still liquid." Ice cream is then pumped into the hollow part. "All of the novelties



Bill Quayle and Milka Mihaljevic sort popsicles before packaging. 150 packages will enter the freezer every minute.

with ice cream in them take longer to freeze than do popsicles, for example, so we have to move the stick machine further up along the line so that the sticks won't be added when the molds' contents are still too soft."

Semi-frozen at the stick machine, the products are completely frozen when they leave the brine and scale a hill. The molds are then defrosted, allowing an extractor to nab the row of sticks and move the novelties, upside down, to the next stage, while the empty molds head back to the filling tank.

Here again, product determines procedure. Usually, the novelties are dipped into a tank filled with cold water, preventing packaging material

from sticking to the surface later on. But if revellos or yogurt-on-a-stick are being made, the required coating is placed in the dip tank instead of water. After going through the dip tank, all the novelties are dropped onto a conveyor and then packaged.

At any of these stages, supervision is needed; people like Mike and **Nick Hrabar** maintain a close surveillance, even to the point of ensuring that the jackets placed inside the barrels to heat the chocolate coating are at the right temperature.

It is a lot of work for all the packagers and operators involved in making novelties, but then, to make something extra out of ice cream takes something extra too.

saycheese, continued

was surrounded by soldiers, and he was subjected to a long, confusing round of interrogations until an educated Egyptian official managed to get him and his crew out safely.

There are so many more stories — Israel, Greece, the Caribbean. But

some of them are not finished, some of the opportunities not fully realized. Presently his boat is in the Virgin Islands. How long — and where next — is anyone's guess. Peter Paget might never answer my first question.

Super Socco Joins UHT Team

Super Socco, a high-energy blend of grapefruit, orange, and lemon juices, will soon join Dairy-Maid on the product lines at the Abbotsford UHT plant.

Super Socco's insertion into the UHT line-up is part of an ambitious marketing game plan to expand the UHT product profile. A wide range of products is required to sustain two full shifts at the plant all year, so Super Socco is being added because of its potential as a high-volume beverage.

"There are three components to Super Socco," comments **George Hrennikoff**, Marketing Manager UHT Products. "It's thirst-quenching and refreshing — the main selling points of a soft drink. But it's also an isotonic beverage, restoring the body's energy and fluid requirements."

As a three-way performer, Super Socco will take a new position in the market — a soft drink product that provides consumer benefits far beyond those of a soft drink. As well, Super Socco will be touted as 'the official thirst-quencher of the Vancouver Whitecaps,' an endorsement which will



The new Super Socco (l) and its California teammate.

certainly help the rookie product in its new market position.

The name Super Socco and the concentrate used to make it have been purchased from a supplier in California who introduced the product to the Los Angeles market a few years ago. In its short stay in the sun, this sharp, tangy, natural drink has rivalled the artificial

drink Gatorade in its efforts to slake the thirst of Californians. Competing against Gatorade, the product has added to its attack by securing the endorsements of two professional soccer teams, the California Surf and the Los Angeles Aztecs.

In acquiring marketing rights for Super Socco across all of Canada and in Washington and Oregon, FVMPA studied Gatorade's failure in local markets and decided to position the product as a 'high-energy soft drink' and not as an alternative to Gatorade. The unique marketing idea, though, has one antagonist. The government. Food and Drug regulations forbid attributing nutritional claims to a soft drink.

As a result, the 'Vitamin C Added' claim has had to be removed from the front of the package. However, original packages, printed before the verdict was issued, will be used for the first few months.

Watch for an explanation of the marketing and advertising strategies selected for Super Socco in an upcoming issue.

Old Way Works

While the Association's involvement in summer fairs throughout the province has increased, the theme of that involvement has remained constant; offer old-fashioned values at old-fashioned prices.

Public Relations Manager **Don Winton** comments on the PNE. "In an atmosphere of hard sell we come across as opposite. Our objective is to present our corporate image and name by putting something back into

the community that's given us our gross sales. We believe in that philosophy, but at the PNE it is less and less evident each year. Consequently, what we're doing is being noticed more and more."

The Dairyland Petting Zoo — family-oriented, fun, and free — is a prime example of the approach. Each year, teenagers of FVMPA staff are there to hand out free Dairyland colouring books. The Dairyland Ice Cream Emporium is another oldie but goodie favourite at the fair. The large, low-priced cones served in an old-

fashioned setting recall the olden days when the Food Fair was a building for samples and services.

Other undertakings at the PNE this year underline the Association's commitment to the agricultural heritage of the fair: a display booth provided samples of UHT milk, handmilking contests involved both professionals and celebrities, sponsorship of events was shared with the 4-H and Dairy Foundation groups, and a Dairyland truck picked up milk from the exhibitors' cows each day.

Continued on page seven

saycheese

It all started four years ago with the discovery of a trunk-full of pictures among her aunt's belongings. Today, Ruth Schafer has assembled her four family trees and placed the names and dates of over 2,200 of her relatives. Her story is one of perseverance and pride.

Starting with that trunk of pictures, Ruth began the arduous task of sorting out who belonged to the side of her grandfather, a hotel operator in Minnesota, and who belonged to her grandmother's side. All of the pictures were then taken to her grandmother's native Wisconsin and to Minnesota to question relatives as to the identity of those in the pictures.

Wisconsin, the site of the original land grant Ruth's relatives obtained when they arrived from Norway in 1850, proved to be fertile ground for Ruth's inquiries. Many portraits were identified and many leads were established: letters, scrapbooks, churches, cemeteries, and municipal offices all needed to be checked for information.

Writing the letters helped her track down addresses as well as unravelling threads of her family history. One letter told of how her grandmother's father walked from Pennsylvania to Wisconsin to locate and claim his land grant and then walked back to take his family out to their new homestead. Church records were also very useful, providing marriage and birth certificates. The birth certificates revealed a common family practice, long since abandoned with the drastic decline in the infant fatality rate; parents would have many of their children die but would continue giving each new child the same name until one lived past childhood.

The information found in the cemeteries proved both valuable and challenging to Ruth's research: valuable in that the stones indicated critical dates, challenging in that when the last of a family line died, Ruth had to decide if the marker of the gravestone — someone from outside the family — had been accurate.

The question of accuracy was also a stumbling block at the many city and town archives Ruth visited. Generations ago, when her relatives emigrated from Norway, the original trunks were stamped 'Hans, son of



Ruth Schafer and 19th Century family, Mr. and Mrs. J. Aikens.

Lerum.' Custom officials, unfamiliar with Norwegian, unwittingly joined the first two words and dubbed the family 'Hanson.' The point that proved aggravating throughout Ruth's research was that some relatives went to court to regain the Lerum name, while others acquiesced and retained 'Hanson.'

The family history has captured the imagination of other relatives as well; one has even written a book tracing Ruth's mother's side back to Nova Scotia and the land grants they

received as United Empire Loyalists in 1784.

Always pushing the research ahead is the surge of excitement and surprise Ruth experiences with a new discovery of a name or date. Recently, when her sister wrote a letter to an archives in Germany requesting that their father's side be traced further, the archives official wrote back that he himself was a relative of theirs. Excitedly, he sent information dating back to 1684. With a lot of work and a little luck, Ruth's story continues.

Announcing a Tradition

War Savings Certificates and Victory Bonds are a part of history — Canadian history and FVMPPA history. It was forty years ago that the sale of War Savings Certificates was launched to help finance the war effort. Many of those certificates and bonds — the forerunners of what we now know as Canada Savings Bonds — were sold in installments on the Payroll Savings Plan. This year, then, marks a special anniversary for Payroll Savings Plans in many organizations across Canada, including FVMPPA. It is therefore appropriate that notice of our 1980-81 payroll plan be given in this special history issue.

The Compound Interest Canada Savings Bond, which is available on our Payroll Savings Plan, has always been popular, even back in the days when buying a bond was tantamount to raising the flag. "A great deal of patriotism went into the buying of those certificates," recalls a Bank of Canada representative. "A lot of

people thought they were giving a donation to the war effort. They didn't even expect to get it back — much less with interest."

Expectations have changed considerably since then, but the advantages of the payroll plan have not. The bond reinvests your money automatically and earns interest on interest, which is paid at maturity or redemption.

Application forms for the plan will be attached to one of your pay cheques in October. Return the form to Payroll by November 10 and money will then be deducted automatically each pay day from the beginning of November to next October. You determine the amount of your deduction; there will be a schedule posted on all the main bulletin boards to indicate the cost of different bond denominations. The bonds you decide to buy will be delivered to you when payment is completed.

The Past is Prologue

We often look back and marvel at how we can put the past under a microscope, uncovering the true significance of the little details that seemed so unimportant then. The little details appear to add up over the years until a new order emerges, a new way evolves.

The past, then, is always an introduction to where we are and what we are today. In this month's issue, FVMPA's past — as told by our

employees — is an introduction for many of us relative newcomers to our modern organization.

Thank you all for your support of and contribution to this section. A special thanks to **Kent Giles, Fred Franks, and Roy Stark** who are absent from the credits of the photographs from Sardis, but who resurrected many of the old plant pictures from the files.

The intention of this section was not

to attempt to give a history of the Association to the employees, but rather to allow long-time employees the opportunity to share some of their past with newer employees. As such, recollections of the past serve to give everyone a sense of how far the Association and its people have come over the years.

Our special history section: read, enjoy and learn.



The Vancouver Heights Branch, 1954. Current employees include Ray Collier and Len Nicol (4th and 5th from left at back), Bill Mehlen (2nd from left at front), and Jim McClatchey (3rd from right at front), who supplied the photo.



'I remember those unhomogenized times when the milkman's arrival signalled the new day.' Route Foreman Alf Edinger's daughter Bev. (1952)

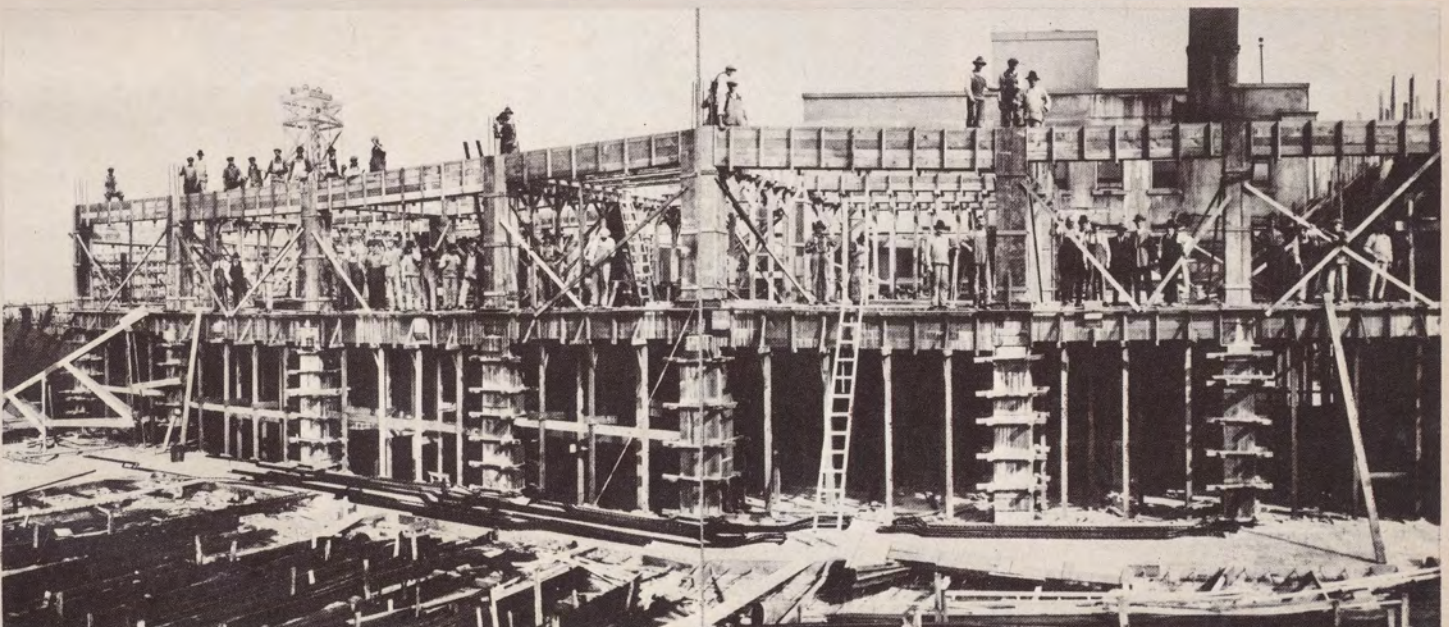

Construction crew pauses for picture-taking during building of Eighth Avenue plant.

Only the Name's the Same

The interview started, as most of mine do, with a check on the spelling of the name. "Hannah, the same backwards as forwards. It doesn't change." Then **Frank Hannah**, retired Assistant Superintendent at Sardis, spent the rest of the interview recalling how virtually everything else **has** changed.

Frank was hired in the spring of 1934; a supervisor spotted him helping some plant employees throw milk cans on to a flat-deck truck. Next morning, Frank had a job, nailing together wooden boxes for butter.

In those days, wood had to be fed into a boiler to produce steam and hot water for sterilization. How the wood got to the boiler was a lesson in transportation; wood piles dotted the back yard of the plant, connected by a network of small railway lines that carried drolley cars loaded with wood into the plant.

It was the wood that kept the plant going in the winter of 1935 — the winter that a stinging ice storm left the Chilliwack area without electricity for over a month. Many of those working at the plant slept there then too, battling to keep fires going.

Incredibly, some production was maintained. The wooden butter churns still rotated, half-full with four thousand pounds of cream and looking very much like over-sized prize ticket barrels. Fresh butter was shovelled out of the churn into the fifty-six pound boxes. Why fifty-six pounds? Forty of the boxes would equal 2240 pounds — a European ton — ready for export.

Low production, though, was not a one-winter phenomenon; since most milk arrived only in the summer, production activity was seasonal. The plant payroll figure peaked in the springs and summers. The total for two weeks in May 1934 was \$2419.88.

All that's changed, of course. Frank Hannah and his wife Hazel have lived through all those changes. Hazel, by the way, is the one who came up with the name **Milk Break** and won \$25 in 1962. Frank reacted to the win by going golfing — with a brand new \$25 golf cart. Maybe some things don't change after all.



Sardis snow scenes. Dairymen bring milk to the plant during winter of 1966, while delivery trucks feel weight of 1967 snow fall.

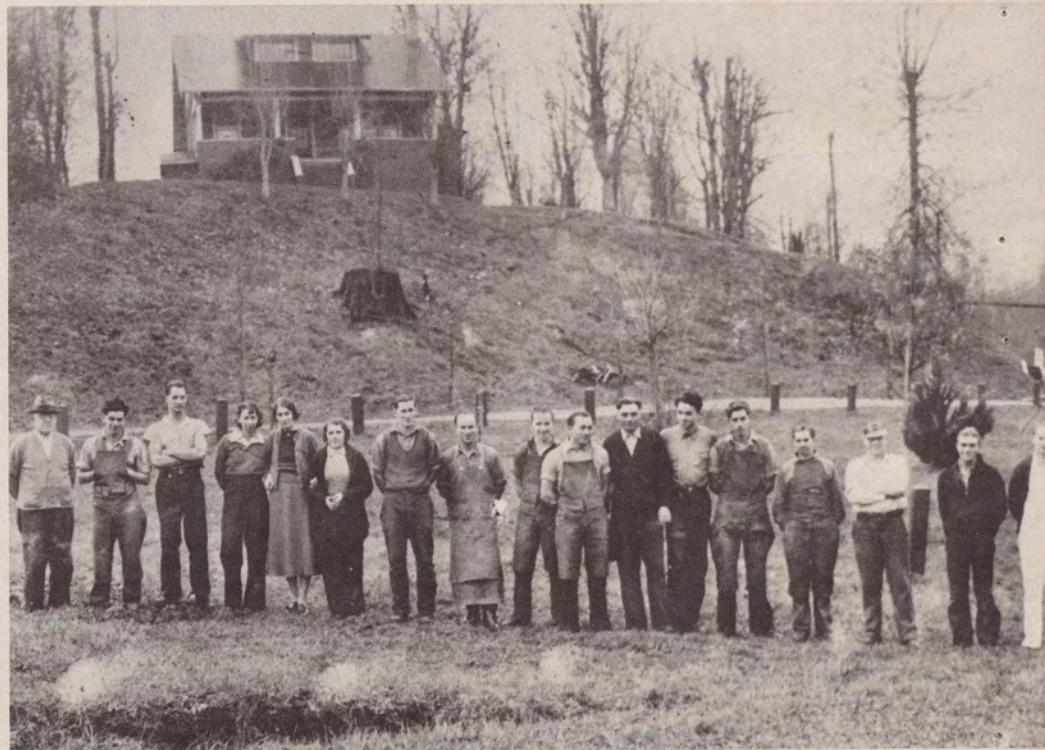

W. C. Chambers, eighth from left and an FVMPA employee for 41 years, supplied this 1937 Abbotsford photo. Superintendent lived on house on the hill.

FRASER VALLEY MILK PRODUCERS' ASSOCIATION

PAYROLL FOR Sardis PLANT PERIOD ENDING July 10 1925

NO.	NAME	RESIDENCE	HRS.	RATE	TOTAL	DEDUCTIONS	NET
1	Paul Chantley	Fraser	24.00	2.50	60.00	2.00	58.00
2	J. J. Bolton	Langston	24.00	3.00	72.00	2.00	70.00
3	Frank Chantley	Fraser	24.00	2.50	60.00	2.00	58.00
4	John Miller	Fraser	24.00	2.50	60.00	2.00	58.00
5	John Brown	Fraser	24.00	2.50	60.00	2.00	58.00
6	A. Brown	Fraser	24.00	2.50	60.00	2.00	58.00
7	H. Schmitt	Fraser	24.00	2.50	60.00	2.00	58.00
8	R. C. Ross	Fraser	24.00	2.50	60.00	2.00	58.00
9	N. J. Brown	Fraser	24.00	2.50	60.00	2.00	58.00
10	C. Brown	Fraser	24.00	2.50	60.00	2.00	58.00
11	H. Taylor	Fraser	24.00	2.50	60.00	2.00	58.00
12	W. Taylor	Fraser	24.00	2.50	60.00	2.00	58.00
13	H. Taylor	Fraser	24.00	2.50	60.00	2.00	58.00
14	H. Taylor	Fraser	24.00	2.50	60.00	2.00	58.00
15	H. Taylor	Fraser	24.00	2.50	60.00	2.00	58.00
16	H. Taylor	Fraser	24.00	2.50	60.00	2.00	58.00
17	H. Taylor	Fraser	24.00	2.50	60.00	2.00	58.00
18	H. Taylor	Fraser	24.00	2.50	60.00	2.00	58.00
19	H. Taylor	Fraser	24.00	2.50	60.00	2.00	58.00
20	H. Taylor	Fraser	24.00	2.50	60.00	2.00	58.00
21	H. Taylor	Fraser	24.00	2.50	60.00	2.00	58.00
22	H. Taylor	Fraser	24.00	2.50	60.00	2.00	58.00
23	H. Taylor	Fraser	24.00	2.50	60.00	2.00	58.00
24	H. Taylor	Fraser	24.00	2.50	60.00	2.00	58.00
25	H. Taylor	Fraser	24.00	2.50	60.00	2.00	58.00
26	H. Taylor	Fraser	24.00	2.50	60.00	2.00	58.00
27	H. Taylor	Fraser	24.00	2.50	60.00	2.00	58.00
28	H. Taylor	Fraser	24.00	2.50	60.00	2.00	58.00
29	H. Taylor	Fraser	24.00	2.50	60.00	2.00	58.00
30	H. Taylor	Fraser	24.00	2.50	60.00	2.00	58.00

70.00 1.24 .60

OVERTIME		TOTAL EARNINGS	INCOME TAX	UNEMP. INSC.	CREDIT UNION	GROUP INSC.	CO-OP SAVINGS	M. S. A.	HOSP. INS.	UNION DUES	A/C REC.	CAN. SAV. BONDS	PENSION
HRS.	AMOUNT												
<p>No 4332</p> <p>EMPLOYEE'S RECORD OF EARNINGS</p> <p>PERIOD ENDING <u>JUN 30 1957</u> 19 <u> </u></p> <p>Fraser Valley Milk Producers' Association</p>													

At left, a Delair payroll sheet from 1925. The only deductions were \$2.00 for road tax and \$5.00 for poll tax. At right, Alf Griffin's first paycheque — ninety dollars for two weeks. During his years at Sardis, Alf has stacked wooden barrels of powder, made casein out of milk and sulphuric acid for use in buttons and combs, and jammed a car spring into frozen milk cans to break ice.

Almond's Ice Cream Company

10th December 1926

To whom this may concern:

This is to certify that Mr. Peter Whyte was employed during the past six seasons as chauffeur and salesman, during which period we have always found him a very careful and capable driver, and an excellent salesman. In the course of his duties he has had considerable handling of cash, and we have always found his records perfectly accurate. We have pleasure and confidence in recommending him to any firm requiring similar service.

Peter Whyte went on to work for Arctic Ice Cream, which later became part of the Association. Today, Whyte's daughter-in-law Iona works for the Association, in the Ice Cream department, naturally.



Sardis cottage cheese production around 1962. At that time, these five-pound cartons were sold retail.



Thanks to Ruth Schafer for this picture of the Eighth Avenue office staff.

A hundred years from now, I dare say, some dreamy collector will pay a cool thousand for an old milk bottle, and I wish I had the equivalent for what my hot-water bag will bring in 2034.

Cornelia Otis Skinner



At left, the big social event of the year, the 1951 bowling banquet. Photo from Cec Brown. At right, Ruth Morrison shares a laugh with J. Girvin (l) and F. Smith (1961).



Around the Plants

He can't remember how much time he spent on the building of the Burnaby plant or how many projects he has managed over the years, but **Don McQueen**, Manager Engineering Services, still thinks he can remember enough old stories to write one more 'Around the Plants' column, a feature that used to appear regularly in FVMPA publications.

"When we were moving from the Vancouver plant to the Burnaby plant in the winter of 1963, we tried to minimize cost and maximize the use of the equipment at the old plant by running machines during the day and then moving them at night. The homogenizer was one of the last machines we needed to move. Five men worked to place a crane on the homogenizer to lift it off a platform built above the roof. The crane went up and the machine — all three tons of it — went down, crashing through

the second-floor roof and taking all five men with it. Luckily, the homogenizer landed first. No one was seriously hurt and the moving continued, minus one homogenizer.

"Back in 1960, we had to design a platform to be used as a dock for both unloading the cases and storing them. Since we knew how many cases we had to provide for, we knew approximately how many square feet of area we needed. But we didn't know the proper length or width. The length would relate to the peak loading time, but we needed some kind of experiment to come up with a measurement — either for length or width. The floor of the dock had been made so that cases would slide easily, so we asked a group of our men to grab a stack of cases with their case hook and start to run with it.

We decided, 'If that's how far they'll pull the cases, then that's how wide we'll make the dock.'

"We all knew there would be unforeseen problems that would emerge during the building of the Burnaby plant. But anyone would have had his head examined had he suggested Sperling Avenue might move all by itself during the construction. On June 13, 1961, a 125-foot section of the road shifted six feet out of line, taking two power poles, a gas main, and a water line with it. Two feet of silt caused the slippage during the earth fill at the new plant.

"Well, Don, since you started building at this site, the birth rate in Burnaby has dropped noticeably.' A planner in Burnaby named Blakely shared that correlation with me shortly before completion of the plant. We were about ready to move in to our new location; what had moved out was Burnaby's one and only drive-in theatre. That's progress for you."

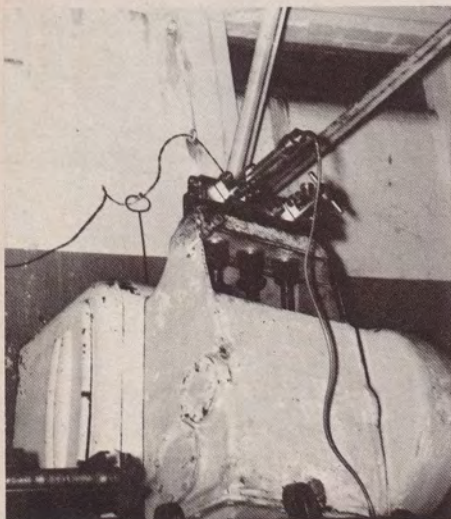

Everyone always seemed to give up around twenty-four or twenty-five feet.

Milk break

Published monthly for the information of the employees of Fraser Valley Milk Producers' Association, 6800 Lougheed Highway, Burnaby, B.C.
 Editor: Richard Muller,
 P.O. Box 9100,
 Vancouver, B.C. V6B 4G4
 420-6611

 INTERNATIONAL ASSOCIATION OF BUSINESS COMMUNICATORS
 IN BRITISH COLUMBIA

skimmings

Picking up on what's been left over, left behind, and left unsaid.

Appointments

Distribution Manager **Bill Hawes** is pleased to announce the appointment of **Don Hobbs** to the position of Branch Manager, Sardis.

Tagged 'Mr. Dairyland' by the Squamish community, Don will move in mid-October from the Squamish branch to his new and larger area of responsibility, directing and supervising distribution at the Abbotsford, Sardis, and Hope branches.

Continued success, Don.

Ray Hurry, General Sales Manager, is pleased to announce the appointment of **Peter Braun** as a Sales Representative.

Peter now begins a new career with the Association following several years in the retail and wholesale operations. He will be based in Burnaby. Congratulations, Peter.

Ad Takes the Cake

Ad Harrington's fellow employees gave him their best wishes and a cake for his retirement. **Bob Fowler**, pictured here presenting the cake to Ad, said that parts of the cake were absent when the photo was taken. "She was too big to fit into the picture," grins Bob.



Milestones

Congratulations to everyone who gave blood during this year's Red Cross Clinic. The donations totalled a record 114 pints. As well, **Mel Hand** donated for his fiftieth time!

What You See Is What You Get

Work began at Armstrong in mid-July to add an observation room to the plant, allowing customers to look into the cutting room, see the packaging operation, and watch cheese in the making. The room, accommodating up to 30 people at a time, is now virtually complete.



Pig-Out Proves Popular

Highlights of the annual Kamloops pig-out, reports **Ron Ratcliffe**, included "intermittent sunshine, sporting events and, of course, the feast itself.

"During the softball game, **Bill McCurrach** entertained with some spectacular fielding antics." They agreed to quit, it seems, when one of the golfing drivers homered "over the mountain, several houses, and at least four ballfields." (take your pick) Recalls Ron, "He followed this feat by putting his derriere through a perfectly good lawn chair, obviously preferring to sit on the grass instead.

"Several members tried their hand at fishing and one tried unsuccessfully to take a nap in a sleeping bag at the end of the pier.

"The ladies' banquet accompanied the barbecued pig, cooked with the master's touch at the site. (for 'the master,' read 'Ratcliffe') Some of the ladies seemed to be restricted in their athletic activities, apparently stricken with a problem common to married women." (careful, Ron)

"All in all, a good turnout and a good day. It's not true that too many cooks spoil the broth!"

Racing for Terry Fox

Bob Hutchinson and **Bob Penner** represented Dairyland in a raft race held on Labour Day to raise funds for Terry Fox's Marathon of Hope. The raft, co-sponsored by Dairyland, was a financial success, its crew raising \$450. Artistically, the raft, consisting of fifteen beer kegs, was a flop, capsizing one-half mile into the race. "The beer strike really hurt our chances," Bob feebly explained.



Tragedy Averted

Special recognition to Valley route salesman **Rod Deakove** for assisting an elderly Maple Ridge woman found unconscious in her home.



Continued from page one

At the annual Armstrong Fair, the Association provided the Old Country Dairyland Store, a display of Armstrong cheddar cheeses, Nature's Treat and Dairy-Maid. Armstrong employees and their spouses were stationed at the store throughout the four-day fair, serving about 5500 samples of Dairy-Maid, many to youngsters who recognized 'the milk with the blue flashing light'.

Whether in Armstrong or Vancouver, the fair days can still be the good old days.

Tomorrow's Dairy Products Today

Meeting with the FVMPA people working on our research and development projects is a bit like stepping into the future. The discussions I had with **Gerry Amantea**, plant bacteriologist, and **Gail Christy**, food scientist, revolved around young, vibrant ideas that may be the predecessors of a family of new products and brands in the coming years.

Current and completed research projects have been jointly funded by FVMPA and federal government organizations. Funds reach the Association only after a sequence of proposal, review, and modification is completed. Then, with the stipulation that progress reports be submitted regularly, the project is launched and researchers begin to turn today's ideas into tomorrow's products.

Three independent projects, conducted from 1977 to 1980 and funded by the National Research Council, centred on the problem of finding a practical use for the eighty million pounds of whey resulting from our operations every year. Out of ten pounds of milk, one can be processed into cheese and nine remain as a watery liquid called whey.

Over the years, whey has been simply discarded as sewage or dried for animal food. A small percentage is sold to bakeries. However, because of new waste restrictions and the shortage of high-quality protein in the world, the push to utilize whey as a food ingredient has been accelerated.

In a series of annual papers presented at the Canadian Institute of Food Science and Technology conferences, FVMPA, in conjunction with the U.B.C. Department of Food Sciences, showed that enzymes applied to cottage cheese whey would break down the milk sugar (lactose) into sweeter sugars. This enzyme can also be added to milk, making it sweet.

The big selling feature here is that the sweetness in the milk comes from the milk sugar already present and not from added sweetness. In the future, enzymes can be used to convert the lactose in U.H.T. milk, resulting in a sweeter product with no added sugars. With flavourings, exciting new products can be developed.

Whey also has potentialities as an animal food. Tests are currently taking



Nancy Baillie is on her case — the ultrafiltration of whey.

place to investigate the effectiveness of substituting whey, in the form of lick blocks, for grain in the rations of young animals. To finance this project, the Association has received \$47,550 from Agriculture Canada, part of which will pay for the services of two technicians during the course of the year-long feeding experiment. All the whey used in the feeding trials is being pressed into blocks at the Sardis plant, where there is a genuine interest in the project; utilizing whey as an energy source for animals would cut the high cost of disposing whey as sewage there.

Other practical applications for whey rely on the physical separation of proteins from the whey. The protein, rich in nutritional and functional properties, has many potential applications both in our plants and in other industries. The industrial equipment available for the separation of protein from whey and the concentration of whey is currently under review.

The surplus of skim milk solids has also been the topic of several research studies. One such study advocated the development of an infant formulation from skim milk solids that would be significantly different from other comparable products on the market. The difference is that the milk is 'humanized' — stripped of parts of its protein and enriched with other added proteins to make the formulation closer to the make-up of mother's milk.

Another study has observed that milk powder can be made completely soluble and tasteless. Two tablespoons of this product could be added to a cup of coffee, causing no change to the colour or taste but adding the equivalent nutritional value of one glass of skim milk to the coffee. In fact, two tablespoons of this skim milk powder could be added to any beverages, including soft drinks, to fortify them with some of the nutrition of milk.

Cheese spreads can be developed from skim milk powder as well. Powder mixed with water and yogurt bacteria is bolstered with enzymes. These enzymes react with the milk protein to create a product similar in flavour and texture to the Cheese Whiz types.

Aside from its own research, the FVMPA often will undertake a project at the request of governmental and other agencies. The government, for example, recently asked the Association to develop a new product. Marketing Department provided specifications as to product texture, flavour and body; **Nancy Baillie** and the rest of the research team began working to make the product possible.

Not all of the research, though, concerns product development; important work in the area of product improvement is also commissioned. For instance, the distinct off-flavour of instantized skim milk has been the subject of much attention. The cause of the off-flavour has been traced to the breakdown of Vitamin A concentrate used to fortify the product and tests are currently in progress to develop a stable Vitamin A concentrate which can be added to the skim milk.

The look into the future that the Laboratory provided was exhilarating. New ideas are always the best long-term asset of any organization; thinking things out fresh today means fresh new products for the Association tomorrow.

New Plant Parts Selected

There are people in Canada, the United States, Holland, Germany, and Australia who know about the cheddar cheese facility at the new Abbotsford plant, even though the facility isn't even off the drawing board.

If you look closely at the drawings and plans for the cheddar cheese room, you see why. Names of machinery and equipment reveal that companies from literally all over the world have been contracted to supply parts for the operation. Many of those parts are scheduled to arrive this fall, now that layout drawings and floor diagrams for the room have been finalized by the Engineering Services department.

Six cylindrical vats, each with a holding capacity of seven thousand litres, will arrive from Holland. At the Abbotsford facility, the cheese will be set in these vats and then discharged to the conveyor-like Alf-o-matic system.

Nicknamed 'Little Alfie' by those in the trade, the Alf-o-matic equipment was designed in Australia and ordered from a supplier in Peterborough, Ontario. The equipment facilitates a continuous flow of cheddar cheese; unprocessed cheese is moved through a series of events which drain, cheddar, mill, salt and mellow the cheese.

Each pound of cheddar cheese also creates nine pounds of the waste by-product whey. Cream will be separated from the whey by a whey separator purchased from Germany. The cream will be cooled and stored at Abbotsford while the remaining whey will be pasteurized, cooled, and transported by tanker to Sardis. At the Sardis plant the whey will be evaporated and dried before storing.

Meanwhile, cheese will leave the

Little Alfie system looking like half-inch square sticks about two inches in length. The cheese now moves up to the top of one of three twenty-five foot chimney-like towers which were bought from an American firm. In these towers the cheese is subjected to a vacuum as well as its own weight in the column, thereby helping to fuse the curd into a smooth dense texture. At the bottom, a guillotine-like knife cuts the cheese into forty-pound blocks which then move along a conveyor belt to the vacuum wrap machine.

Depending on the type of cheddar cheese to be made, these forty-pound blocks will either be cured for three, six, or nine months and then cut into package sizes.

The whole processing system requires no hoops and no vats, few of the parts usually associated with the open vat system of cheese making. Once completed, the cheese room will house a highly modern operation producing three thousand pounds of cheddar cheese per hour with equipment purchased from three different continents.

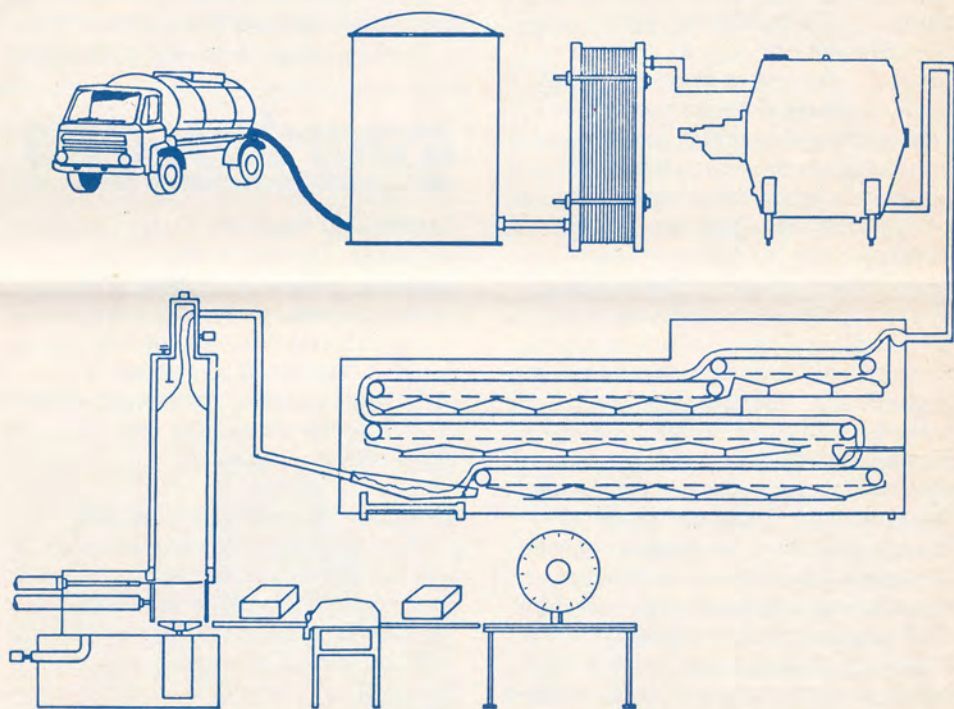

Milk is received in a silo, heat treated and then placed in a cheddar tank. The cheese then flows through the Alf-o-matic and is pushed to the top of a tower-like block former. At the bottom of the tower, cheese is cut and then sealed and stored.

Out to Corner a Market



By now, you've probably seen the Super Socco commercial on television. The one that jolted you out of your armchair while you dozed through the late movie, remember?

That high-energy attack on the senses was a deliberate one, calculated to make Super Socco's entry into the soft drink market memorable. The television commercial is the advertising showpiece of FVMPA's first entry into the mainstream beverage market. Two million litres a year — one percent of total B.C. sales — is the initial marketing objective.

A limited media approach had been adopted for Super Socco several years ago by the original distributors of the product, who used radio, print, and point-of-sale material to introduce Super Socco to the Los Angeles test market. FVMPA liked what they saw but observed one way to do it better — the use of television. That medium allows the advertiser to portray the product and any new product relies on some sort of registration when the consumer sees it on the shelf. So when the Association purchased the marketing rights to Super Socco, **George Hrennikoff**, Marketing Manager UHT products, told Westcan Communications that a thirty-second television commercial for Super Socco was 'a definite go.'

Westcan must have taken George literally. Go indeed; nothing in this commercial slows down. "We decided to portray the product in an active lifestyle situation," understates agency representative Allan Levy, "similar to the way you recognize other soft drink makers selling their products." Produced in Vancouver, using a local production company and local actors and actresses, the commercial is a triumph of details: the specially-constructed stage was shot at the old Uncle Ben's brewery warehouse, and fifty pieces of three-foot fibreglas fruit



A shot from the current television commercial.

joined huge potted plants on a stage-full of dancers. Even the running shoes were specially-made. The piano? Baby grand, of course.

The commercial will be shown in two phases: during the six-week introduction this fall and then again during the fourteen-week main launch in the spring. A radio commercial — a voice heard over the same fast-paced jingle — will act as accompaniment to the overall theme, 'Move Over Pop.'

The objectives of the advertising and

public relations efforts are to portray Super Socco to the mass market as a thirst-quenching beverage for active people. "But we have to convey Super Socco's qualities indirectly," outlines Levy, "because the Food and Drug Act won't allow the advertising of a high-energy soft drink. We can't say 'high-energy,' so we have to show high-energy."

Just don't sleep too close to your television set, that's all.

sportscoops

Undefeated Season

Dairyland's team in the B.C. Amateur Football Association's fall recreation league has completed a highly successful season. In fact, it couldn't have been any **more** successful: six wins, no defeats, a total of 269 points scored and only 14 point allowed.

Women's Hockey Isn't Slapstick

They started out about a decade ago not wearing face masks and using their figure skates. Now women's hockey has gone big league in B.C., with full uniforms, sponsorships, four divisions, and an entertaining brand of game that stresses skating and shuns hitting.

Roger Ruddy, Burnaby Stock Room, became involved as an assistant in the sport eight years ago

when **Barb Nutall**, Purchasing, was one of the original founders of a Coquitlam team.

"I could hardly skate then," admits Roger. Over the years, as the team has taken part in tournaments across Western Canada, Roger's role has become "trainer, goaltender coach, and mouth." His wife Val now also plays on the team.





saycheese

The gold is gone. All that glitters now from the early gold rush days in the Yukon are the stories, outliving their settings.

Bud Mason of the Number 1 Stock Room in Burnaby can tell many of those stories. His parents caught the Yukon gold fever in 1900 and spent the next eighteen years in Dawson City, his father working as a transportation manager for a gold company and his mother a court stenographer in that lively and often lawless town. Bud's whole family from his mother's side moved up to Dawson when it was still just a tent town. Bud's uncle discovered the richest silver mine in the area and



The early shorefront of Dawson City, Yukon.

named it after his wife, calling it the Sadie mine.

Even though some hardy miners struck it rich on their own, most of the gold and silver was uncovered by placer mining, using a dredge to mine the ores above ground. They could dig day and night during the long summers; Bud still has pictures of the town taken in the midnight sun in 1906.

A few years later, local wars, like tremors before the eruption of the First World War, began to be felt throughout the world. In Dawson City, Bud's mother wrote letters back and forth to a man she had become engaged to who was serving in the

Turkish War, a man by the name of Robert Service. Acting then as an ambulance driver, Service later became one of Canada's best-known poets.

Service died of old age in France. Re-united with her husband, Bud's mother stayed in Dawson until October 1918, the month the steamship Sophia struck a reef, foundered between Skagway and Juneau, and sent 343 passengers, most from the Yukon Valley, to their death. All that survived was a dog. The disaster left Dawson City a ghost town, as remaining residents left quickly to escape the memory.

Retirements

Who was the supervisor when the Association first started out in Richmond, delivering just one case of milk and that to a staff employee? The year was 1951, the man **Charlie Webster**, retiring branch manager at Sardis.



At Sardis for the last decade, Charlie has handled wholesale and retail distribution, sales rep duties, and "anything else that's come up" in his area. He looks forward to enjoying his retirement winters in Arizona with his wife Carmel as well as pursuing his interest in antiques.

Jack Townsend, Burnaby Production, officially retires this



month, although leg problems forced him to leave his job in January. An employee since 1966, Jack witnessed first-hand the automation in the ice cream department.

Jack first began making ice cream in a dairy in Saskatoon after years of hauling cream and eggs from the farm to the dairy. Out west for a holiday, he decided to move here. Vancouver will continue to be Jack's and his wife Lillian's home during their retirement.

Milk Break reminds all employees that part of the Dairyland Employees Charitable Donation Fund's purpose is to provide gifts to retiring members of the fund. Membership information is available from **Jim Defries** or **Darryl Palmer** at the Burnaby plant. You can also call **Milk Break** for any other information on retirements or retirement-related activities.

The Keepers of Quality

Mention security — safeguarding the assets and investments of the Association — and you probably don't think of Laboratory services. But ever since FVMPA added its first bacteriologist to its payroll in 1923, laboratory staff have been working to protect one of the most important assets — the quality of milk.

While the laboratories also research and develop new products and product formulations — the subject of one of last month's features — the majority of time and effort is spent on quality control. Our perishable products demand constant and continuing attention.

The lab's search for tell-tale signs begins at the farm and continues through to tests on processed milk samples.



At left, Lori Milot shakes bags to get a homogeneous sample in preparation for grading. At right, Mariam Franson counts grades on the plates.

Checking I.D.

To identify each dairyman's milk, the farm pick-up drivers take a small aseptic sample of milk in a "whirlpak" pouch (you have to whirl the pouch to seal it) from each farm.

This sample milk is first tested for bacteria levels. The total of sample milk picked up over fourteen days, called a composite sample, is then evaluated for a variety of characteristics. At the Burnaby lab, **Ron Pelzer** organizes the composite samples and then sends them to the Dairy Branch where they are analyzed for protein, lactose, and butterfat contents.

Counting Clues

They may be microscopic, but too many bacteria can have some large and lasting effects on the quality of milk. While a count of greater than 75,000 bacteria per millilitre constitutes low-grade milk under the Milk Industry Act, greater than ninety percent of FVMPA producers ship milk with less than 3,000 bacteria per ml — well under the level the Act considers acceptable.

Several different tests determine the quality of that milk, namely the standard plate count and the lab pasteurized count.

The Burnaby bacteriology team — **Miriam Franson, Tom Galinis, Lori Milot, and Gail Smart** — have all been trained to conduct these tests.

In the standard plate count the milk is added to a specially-designed culture media, which supports the growth of bacteria, and a period of incubation then follows. The pasteurized count, as its name implies, heats the milk hot enough and long enough to duplicate the pasteurization process.

Bacteria counts are then taken. The count in the pasteurization test gives an indication of the initial quality of the raw milk following pasteurization — valuable information for the producers. Heading the investigations of these results are fieldmen **Ed Fridriksson, Al Kroeker, and Mike Yusko**, who work on any bacteriological problems with the producers and may, for example, help them make changes to their milking equipment.

Getting to the Bottom of It

Twice monthly, the Dairy Branch — the government lab — takes a sample of milk from the bulk tank to determine the number of somatic cells, which are indicative of early signs of

mastitis in cows. In addition to these tests, the Burnaby lab does a Milk Gel Index test, another method for tracing incipient mastitis.

The milk index test is simple and quick; milk is made to react with a coloured soap solution to find out how much of the milk will thicken. In other words, the milk's degree of viscosity is determined. Suspect milk thickens (has more viscosity) while normal milk remains liquid.

The milk that thickens settles as a blue jelly at the bottom of a test tube. By measuring the amount of jelly left in the tube, the number of somatic cells per millilitre of milk can be approximated. Too many somatic cells means mastitic milk.

Milk break

Published monthly for the information of the employees of Fraser Valley Milk Producers' Association, 6800 Lougheed Highway, Burnaby, B.C.
Editor: Richard Muller,
P.O. Box 9100,
Vancouver, B.C. V6B 4G4
420-6611

INTERNATIONAL ASSOCIATION OF BUSINESS COMMUNICATORS
IN BRITISH COLUMBIA



Gail Smart composites shipper samples for milk analysis at the Dairy Branch.

A Dead Ringer

Milk samples are also tested for the presence of inhibitors — in other words, anything that will prevent the growth of bacteria. The guilty inhibitor might be as commonplace, for instance, as the chlorine used to sanitize milk equipment. The antibiotics used to treat mastitic cows are another possible suspect.

In the inhibitor test, an absorbent disc is dipped into a milk sample, then placed on a petrie plate with a fast-growing bacteria culture and incubated. A clear ring appearing around the disc means that the bacteria have been inhibited.

Inhibitors pose a real threat to many dairy products; the production of cultured products like cheese, yogurt, buttermilk or sour cream is not possible if the milk contains any inhibitor.

The Sardis and Abbotsford labs are also involved in rigid quality control.

Cat and Mouse

At Sardis, **Muriel Branch**, **Bruno Lampart**, and **Bob Millard** ensure that products like cottage cheese, powder, and butter meet the highest standards possible.

Some of these dairy products at the Sardis plant require special lab attention; the cottage cheese, for example, can be infected by phage, a bacterial virus that can infiltrate and destroy the culture, preventing it from thickening.

In any cottage cheese culture, there are a number of different strains of bacteria; all the strains are related but each is a little different from the others. For each strain there may be a specific type of phage that will prevent the growth of that bacteria. Phage A₁, for example, will only damage strain A₁.

The lab, in an attempt similar to a cat and mouse game, continually tries to switch one starter strain with another just before the phage begins to have an effect on the first one. This then forces a large group of phage to go up against a new strain they cannot fight.

Testing UHT Milk

The new UHT milk at Abbotsford requires some rigid tests new to the lab. **Craig Maishment**, **Jean Wate**, and **John Wegenast** are initially sampling one percent of the total product — a high rate reflecting the



Muriel Branch and Bob Millard — two-thirds of the Sardis laboratory team. Missing from the photograph is Bruno Lampart. At right, John Wegenast from the Abbotsford lab uses a pipette on one of the many lab samples of UHT milk.

desire that the new product be absolutely sterile.

UHT milk is sterilized by direct steam infusion into the milk, followed by a vacuum treatment. The lab determines the effectiveness of the vacuum by monitoring the milk for any increase in water. This is done using an instrument called a cryoscope.

The cryoscope is one of the latest pieces of the lab's hardware, a machine that freezes one millilitre of milk in a special tube. Regular milk freezes at a specific temperature. Any deviation from this temperature, suggesting more or less water in the milk, will be recorded by the cryoscope.

UHT milk is also subjected to standard plate counts, acidity tests and shelf-life tests. To complete the rigid testing schedule, the carton itself is checked; a dye is used to determine any possible faults in the carton integrity, while a conductivity test helps detect leakage. In the latter test, a Tetra Brik package filled with a salt solution is placed in a water bath. A probe in the water registers any solution that has permeated the carton; in this way, even microscopic leaks can be found.

So don't let the calm, clinical surroundings fool you; what's at stake at the Abbotsford, Burnaby, and Sardis labs is the quality of FVMPA milk. It's that quality-proven milk that continues to be the best form of security for the Association.



skimmings

What's news at the Association this month

Appointment

Bill Hawes, Distribution Manager, is pleased to announce the appointment of **Wayne Brown** to the position of Supervisor at the Squamish branch. Previously a route foreman at the Campbell River branch, Wayne now assumes new duties and responsibilities.

Welcome to your new position, Wayne.

Sunshine on her Schedule

Judy Davies, a food scientist here this past year, is planning to follow the sun for a year and work on dairy farms at the same time. On October 25th, Judy left with others in the International Agricultural Exchange Association for six-month stays first in New Zealand and then in Switzerland.

During both visits, she will be working and living on a dairy farm. "I have a degree in Agriculture," Judy comments, "but this is the first time for me as a farm kid." The initiation will be complete; Judy will even take lessons in New Zealand to learn how to drive on the other side of the road.

The entire trip is an opportunity to get international experience in dairy farming. Switzerland has a strong dairy tradition, as does New Zealand. Where else to milk cows but down under?



Presentation

On Friday, October 17, **Darryl Palmer** presented a cheque from the Staff and Welfare Fund for \$10,000 to support the activities of the United Way throughout the province. Accepting the cheque was **Bob Kayser**, President of the 1980 United Way campaign.



Hurrah Turra

Congratulations to **Tony Turra**, Assistant Shipper at Delair, on his efforts to collect money at the Pacific Milk plant for the Terry Fox Marathon of Hope campaign. Tony's extra time resulted in one hundred eighty more dollars to the cause. Special thanks as well to those who donated.

Care to Dance?

The Dairyland Fall Dance takes place Saturday, November 22. Held this year at the Engineers Hall in Burnaby, the dance costs ten dollars per couple, including eligibility for a door prize. Tickets are available from **Jim Defries**, **Darryl Palmer** or the Stationery Department.

Clymer Goes Back to School

One of the large John Ford Clymer paintings was temporarily taken from its Burnaby office surroundings to be reunited at the new Emily Carr College of Art on Granville Island with other paintings and sketchings from 1925-1939 artists. The inaugural exhibition features the work of early Vancouver art students such as Clymer.

Milk in Olde England

Retired driver **Reg Peckover** recently returned from England where he found the home milk delivery system very different from our own modern one. All milk is sold only in pint bottles — the majority still having the old foil-type cap — and distributed mainly by three-wheeled electric trucks.

The trucks have no refrigeration whatsoever, for milk is delivered seven days a week. A driver may have to

work every day, keep his own books, and collect on his accounts on Fridays and Saturdays. On those days, then, he is virtually doing the route twice.

Reg estimates that the largest milk trucks in England are about the same size as our retail trucks.

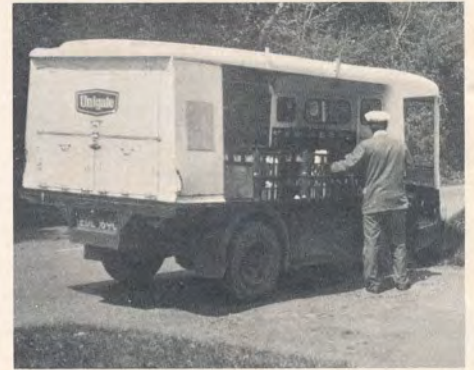

Condolences

Alf Griffin, Charge Hand in the Sardis powder production department, died in Brooks, Alberta on Friday, October 17. Alf, an avid outdoorsman throughout his life, died of a heart attack while hunting. He was also a gifted gardener who gave many plants and vegetables to staff. Those who knew Alf during his forty-one years with the Association — those who watched him work almost every piece of equipment at the plant — extend their support to his wife Georgina and his son Dan.

Bring On the Pink Milk

Since its introduction, Dairy-Maid, the fresh milk that needs no refrigeration, has answered many needs, including one expressed eight years ago.

In August of 1962, Agriculture Minister Bill Richter urged dairy farmers at the annual FVMPA picnic to go all out to boost the sale of milk — even if they had to sell pink milk and take their products in vending. "You can say what you like about pink elephants, but they are selling pink milk in Europe."

At that time, FVMPA's public relations manager Jack Gray agreed with Richter that new markets for fresh milk should be actively sought, but added "the big problem is that you are dealing with a perishable product. The machines would have to be serviced every day."

Today, thanks to Dairy-Maid, fresh milk is available without refrigeration to many new consumer groups. Dairy-Maid affords the opportunity to look into other markets in the future, including vending.

Now, about that pink milk . . .

That's Your Credit Union



Credit union staff, from left to right, are Louise Cumming, Ken Ma, Robert Conley, Gord Aasen, and Jan Chapman.

The Dairy Industry Credit Union was incorporated in 1943 to service the needs of twelve Dairyland employees at a time when "you needed a thousand dollars to borrow five hundred," quips present manager **Gord Aasen**.

Under Aasen's management today, the credit union has about 1650 members who collectively own over 600,000 shares. The first million dollars in assets was reached in 1968; assets under administration currently top \$8½ million.

Impressive progress for an organization that at first concentrated only on issuing shares and loans. It is progress that can be explained by the

trite but true adage, 'make the most of your opportunities.' Once the opportunity to take care of their own money matters became available to the employees of the Association and their immediate families, they used it well. They have continued to use it, widening the range of financial services of the credit union as their needs as members have increased.

The present credit union, operating under the provincial Credit Union Act, offers chequing, non-chequing, Plan 24, and term deposit accounts and also provides daily interest. The only real difference between the Dairy Industry Credit Union and others is a logical one; there are few business

loans conducted at this credit union because of the fact that it exists primarily for people already employed at FVMPA.

"We're here to serve a specific customer," explains Aasen, "so we know our customers well. We can provide a personal approach seldom found in the larger financial institutions." In this age of the super bank and the super bankers, the credit union does things with a difference: as a member, you can arrange to have payroll deductions transferred directly into your savings account, receive free chequing privileges and free traveller's cheques, and pay no money order charges if you are fifty-five or over.

As a non-profit organization, the credit union also sets its rates differently than do banks and trust companies. "We try to keep our rates level," Aasen states. "Our RRSP interest rate, for example, will remain at a steady 10½ - 11½ percent over the same period of time that the banks will prop up their rate to 12 percent and then drop it down to nine. There are also no administration fees with the Dairy Industry Credit Union RRSP, and no hidden fees, such as start up costs."

Those advantages, coupled with the luxury of having access to your money where you work, may be enough for you to make the dairy credit union your credit union. Purchasing twenty-five dollars worth of \$1 shares will make you a member.

A Double E in Ed?



E.E. (l) and E. Novakowski

You would think that with a last name like Novakowski, you would have no problem with a first name like Ed. Not so.

Ed (Edmund) Novakowski, Branch Manager at Williams Lake is E.E. (Double E) Novakowski, if you will. And anyone who begs to differ has to reckon with Distribution Manager **Bill**

Hawes, who hit upon the 'Double E' idea after months of confusion had been caused by the case of the two Ed Novakowski's.

The other Ed, you see, is **Edward Novakowski**, brother of Ed, er, Double E, and also an FVMPA employee. He's a route driver at Burns Lake, and is known (you guessed it) as Single E Novakowski.

Both brothers had worked for Dutch Dairies (Armstrong Cheese) up until the Association purchased the dairy in 1977. Both were hired by the Association; it was not long before this double identity turned into an FVMPA situation comedy.

Recalls E.E., "Mail and memos were sent out to Edward and one time even my expense cheque was sent to him as well."

That was just about enough, even

for a big friendly guy like E.E. "After three months, I received a call from Bill Hawes; it must have taken the head office that long to sort all this out and realize there was a problem," he teased.

There was, though, a real need to come up with a practical solution. Bill suggested to Ed in Williams Lake that perhaps he could try and add another initial to his name and simplify things a bit. Replied Ed, "I added another E just to keep confusion out of my own life." At that point Bill decided, "That makes you Double E and your brother Single E."

Problem solved? I wouldn't get too smug about it. All told, there are ten brothers and five sisters in the Novakowski clan. With all those children, chances are there's another Ed Novakowski lurking out there, filling out an application at some FVMPA location.

A triple E in Ed?

Workplace

Coping with Stress



Periodically, **Milk Break** will publish a feature entitled 'Workplace,' a series of articles on the work environment — the factors around you that affect the way you do your job. In this month's 'Workplace' article, **Bob Lefluffy**, a North Vancouver management consultant, talks about coping with stress.

"Would you tell me, please, which way I ought to walk from here?"

"That depends a good deal on where you want to get to," said the Cat.

"I don't much care where. . ." said Alice.

"Then it doesn't matter which way you walk," said the Cat.

". . .so long as I get somewhere," Alice added as an explanation.

"Oh, you're sure to do that," said the Cat, "if you only walk long enough."

There are many more passages like this one in Lewis Carroll's **Alice in Wonderland**. This is no ordinary fairy tale; our girl Alice is under stress.

What are the symptoms of this 'Alice in Wonderland Syndrome,' as Bob Lefluffy terms it. "Alice has no goals," outlines Bob, "and she seeks help, not in an effort to set goals for herself, but in an effort to avoid having to do so. She asks for direction, and insists that the cat provide it. Alice is also inclined to be angry a lot; she possesses a sort of low-grade hostility towards others, and



"You seem to feel alienated . . ."

it shows up in many of her interactions with the people she meets in her travels. It seems to bubble up from just under the surface with surprising regularity."

If Alice sounds familiar to the modern reader, it's because her actions and behaviours are strikingly similar to what some people accept as 'normal' behaviour, and represents what is often the socially acceptable pattern of responses to a stressful situation. If the realities of a job are such that one feels 'burned out,' it only seems natural to act like Alice.

That is why it is often so hard to identify early stages of 'burnout;' there is a tendency to consider our early reactions to stress as normal and temporary. "Burnout does not happen instantaneously," Bob explains, "but moves through stages. At the physical fatigue stage, you simply feel drained. A good night's sleep used to get you back into form, but not any more."

"If you don't realize this as an early sign of possible burnout, you move to the stage at which we pinpointed Alice; frequently irritable, feeling very much alone, alienated, tired and bored. Soon, your situation will parallel Alice's fundamental sense of herself as a victim, an object of the action around her rather than the subject of that action. Things happen to Alice; she does not accept that she has any responsibility for her situation. She merely looked down a rabbit hole, and doing that wasn't really her fault anyway, she was bored."

In a work situation, the overriding questions at this psychological point deal with levels of effectiveness (Do I really have an impact on my job?) and values (Who am I doing all this for, anyway? Is it worth it?). If the answers here don't revolve around the goals the individual has set for himself and his job, then that individual usually moves to another job, another work setting where he hopes things will be different. "It'll be better over there," he bargains.

It usually isn't any better; if a similar stressful situation develops, the temptation to blame it on factors outside your control increases. The only way to cope with stress is to manage it, to use your own resources against it. Set goals. Know what you want and what is expected from your job.

Employers and employees both play a part in this important realization. Managers and supervisors play a role in the staff members' efforts to help themselves. One of the ways in which supervisors can help is to examine the structure and processes in their departments, determining if there is enough room for personal goal-setting and growth.

Observes Bob, "Most individuals have drives toward personal growth and development if provided an environment that is both supportive and challenging. Most people want to become more of what they are capable of becoming."

To conclude, any job carries with it a certain amount of stress; that's certainly normal and also healthy in a work environment. Losing the ability to cope with increased stress — a promotion, a new responsibility, for example — often begins so gradually that that reaction appears normal too. An individual develops various outward symptoms such as lassitude and anger, and then begins to withdraw, increasingly alienated and cynical.

The issue is really power; to what extent do you perceive yourself as having the authority to overcome the problem? Employees need to create goals and employers need to create environments in which these goals can be met in order to overcome many of those stress-related problems.

Future Growth and Needs Analyzed

Long-term planning is a key prerequisite for efficient management of any organization. At FVMPA, there has always been long-term forecasting; the Burnaby plant, in fact, was built in 1963 on sales and volume projections for 1980. Even though those projections were actually surpassed ten years earlier, they played an important role in the decision-making process. Predictions made this year will now help the FVMPA plan for the decade ahead — a decade **Don Winton**, Marketing Services Manager, describes as “potentially the most dynamic ten years of the FVMPA.”

Winton's confidence in FVMPA's future performance derives from a recent trend analysis and sales growth projection. Statistics released from the B.C. Research Council indicate that the population of the province in 1991 will top three million, equalling an increase of nineteen percent over this year. Increased numbers in B.C. will add force to the upward trends in per capita consumption of many dairy products, particularly fluid milk and cream, cheddar cheese, yogurt, and cottage cheese.

Those upward trends are already heavily supported by existing evidence. FVMPA's average growth rate for the complete line of products over the past three years has been a substantial seven percent. For individual product groups, the average annual increase has been spectacular — as much as thirty-two percent, for example, for portion (Gasti) products. Machine technology responsible for the Gasti equipment, product technology responsible for Nature's Treat, the acquisition of Armstrong

Cheese, the marketing programs, and the distribution network have all contributed to the Association's growth.

Projecting that seven percent average per annum unit sales growth over the next ten years signifies a virtual doubling of unit sales in the decade ahead. “And that prediction is only a very conservative one,” intimates Winton. “The seven percent increase is based on our existing product range and does not really account for the possibility of new products. For example, when we forecasted yogurt sales several years ago, we did not anticipate the separate market for natural yogurt that exists today. Within this present projection, then, there has to be a factor for new product development originating out of both lab and consumer research.”

Winton also mentioned the export and UHT markets as significant growth areas that could help lead to a doubling of unit sales even before 1990. “In export, there is a market for UHT products, bulk cheddar, evaporated milk, and skim milk powder, but there is also a very lucrative fresh milk market in milk-deficient countries — particularly those along the Pacific Rim — if we can overcome the major problem of transportation costs.”

Any firm needs assets — plants, equipment, and machinery — to make sales; if unit sales are to increase greatly in the next ten years, what expansions to assets can be expected? **Jim Byers**, Engineering Services, outlines some of the areas that will undergo change in order to meet new demands. “In terms of shipping and

receiving,” points out Byers, “we will have to double the loading-out facilities into the trucks and also build a drive-in arrangement for tankers so that they no longer will have to back in. Presently, we are reaching a situation where we can produce more milk than we get out of the plant.

“Many of the machines in production are running close to or at their capacity. We will need to double our pasteurizing capacity; we can do that without taking up any more space on the production floor by purchasing a pasteurizer with increased volume capability.”

Byers also indicated that another Gasti machine will be required. “Perhaps an aseptic one will be purchased,” he suggests. “By lengthening the shelf-life of the milk, cream, juice, drink, yogurt, and pudding Gasti products for a day or two, we would be encouraging hospitals and other institutions to order in larger bulk quantities.”

In regard to ice cream, continues Byers, low-temperature capacity will be doubled with the addition of an added low-temperature room. “In the interim, we have ordered a quick-freeze tunnel for ice cream production use, which is scheduled to arrive late in 1981.”

Other equipment, such as trucks for distribution, will obviously also increase in numbers as sales increase. By anticipating future growth in all areas of the product range, future requirements in terms of equipment, machinery, space and volume can be planned for today. “We rarely play catch-up,” emphasizes Winton. Success demands that we never do.

Products Here for the Holidays

Each year at this time, the Association markets a line of products especially for Christmas. Tis the season — from the beginning of November to New Year's Eve — for Dairyland egg nogg and various special ice creams.

Planning for the annual Christmas lines dates back to the first week in September when fruit ingredients are ordered. Packaging is sent by the first of October.

Three different flavours of ice cream are packaged each holiday season: festive fruit and peppermint candy in the two-litre sizes and Christmas swirl in four-litre. **Ron Brown**, Assistant Plant Superintendent, describes festive fruit as "ice cream with a twelve to fifteen percent mix of maraschino cherries, pineapples, walnuts, and other flavour bases and mixes.

"Peppermint candy ice cream," continues Brown, "is red and green crunch added in pieces like a shotgun blast to the ice cream mix. Christmas swirl also contains red and green ingredients but in ripple form."

The most popular ice cream product at Christmas is the log roll, with sales of approximately 40,000. Production of log rolls takes place over a four-week, labour-intensive period. Five people a day assist the operators handling the galvanized one-litre tins used to make log rolls.

Ice cream is added to the tin, one end of which is open, the other punctured with a small hole. After the tin has been frozen, it is spun in a hot water tub to release the ice cream from the sides of the container. The small hole allows air to replace the ice cream that slides out. The ice cream

now is rolled in a coating of toasted coconut and nut and chocolate pieces and then packaged.

Dairyland's Christmas drink every year is egg nogg, the festive favourite that reaches seasonal sales of 400,000 litres on our wholesale and retail routes. Blended in a vat and then pasteurized, egg nogg, in its final form, contains five percent butterfat.

To merchandise all the Christmas products and to extend Christmas wishes to consumers, a commercial will appear on Hockey Night in Canada for three Saturdays in December. The commercial, explains **Don Winton**, Manager of Marketing Services, will carry the flag for all the Christmas-related products, including 1886 ice cream, sour cream, and whipped cream.



Retirements



Bill Mason, sterilizer operator at the Pacific Milk plant, retired this month after thirteen years at Delair and twenty-five years total service to the Association. Bill started as a retail driver at the Vancouver Heights branch in 1956, using a half-ton open Divco truck that he had to stand up in to drive. After several more years as a wholesale driver, commuting daily from Aldergrove to Burnaby, he received a transfer to Delair. Bill will spend his retirement relaxing at his mobile home in Clearwater with his wife Bessie.



Vivien Edwards sends word that **Lyle Steward** has set December 12th as his retirement date. Lyle has been a butter-maker at Sardis for thirty-two years. Travelling, hunting, fishing, golf and square dancing are the pastimes Lyle and his wife Frances are intending to enjoy more of in the near future, after they have arranged their mobile home the way they want it.

Len Enyedy at the Delair plant used up a few months of holiday time owing to him to retire early this fall. An immigrant from Hungary thirty-two



years ago, Len has worked almost thirty years at the Delair plant and is grateful for the opportunity this country and this Association have given him. Over the years, Len worked with the automatic sterilizer, the packing machine, and the equipment in the canning room. He also served as night watchman for several years. Retirement plans for Len and his wife Juliana include a return trip to their home country.

Best wishes to all of you for a long and enjoyable retirement.

Shooting for An Audience



In between all those shots on goal every Saturday night, hockey fans are getting a look at Armstrong cheese commercials.

Contrary to popular belief, those hockey fans are not all men. "When we first became local sponsors of Hockey Night in Canada last year, we realized that a substantial portion of the viewers were women," states **Don Winton**, Marketing Services Manager. "That was an important fact to us as

potential advertisers, because, although men influence the buying decisions, they don't usually make them."

Hockey Night in Canada's demographics — the age group, income level, and geographic location of its viewers — make it one of the most attractive television shows for advertisers. "It's not easy to get on during the game," confirms Winton. "Because of the high demand, most

advertising time is consumed by the national sponsors — the major oil companies, for example. What's left over goes to the local sponsors like us. Your corporate image is enhanced by appearing on Hockey Night in Canada, because the audience identifies you with the major prestige companies."

The Association contracted for a full season of advertising for the first time last year and renewed its option this year again. The theme of the province-wide campaign is "Armstrong, B.C. — You've Got Good Taste." Outlines Winton, "The theme conveys a dual message: Armstrong cheese is a B.C. product and also a high-quality product made with pride. The messages help create product differentiation for Armstrong in a highly competitive market."

Winton analyzes the advertisements, "The secret of the product is pride while the uses of it are many: Armstrong cheese can be included in meals, snacks, and sandwiches."

The multi-media campaign — which includes outdoor and shelter magazines as well as television — has helped extend distribution of the product into every major supermarket in B.C. "We're creating a demand," points out Winton. "Retail chain store managers see the marketing activity, generating movement for the product."

saycheese



History doesn't always repeat itself; sometimes you really have to work to bring back the good old ways.

Al Wheatley (at right), Burnaby Workshop, has saved one old tradition from desertion. As Vice President of the British Columbia Commemorative Royal Engineers Company Society, Al has spearheaded an attempt to restore



some of the pageantry associated with the age of black powder.

The purpose of the Society, of which driver **Kelly Nielsen** (at left) is also a life-time member, is to re-establish a commemorative regiment, similar to the Ft. Henry Guard in Kingston, Ontario. Such a regiment will be a lively and colourful addition

to many local celebrations.

At the recent Golden Spike Days in Port Moody, for example, the regiment fired off its cannon for the opening ceremonies. As well, Al and his wife won the costume award for the Golden Spike Days' best-dressed couple.

The Society's dedication to tradition has attracted the attention of B.C.'s Lieutenant Governor Henry Bell-Irving. Last year he agreed to be the Society's patron; this year Al and his wife attended the Lieutenant Governor's tea.

Too many events today have lost their historical significance, too many holidays only hollow reminders of the past. Thankfully, Al, Kelly and the rest of the Society members, rifle and top hat in place, still come dressed for the occasion.

The Energy Challenge

Undoubtedly the key word for the eighties, economically and politically, will be energy. The steady depletion of the world's most accessible reserves of oil and gas has brought on a new and costly reality; as conventional supplies slacken, both the demand for them and for new energy sources intensifies. While the normal flow of energy has always been the lifeblood of manufacturing and processing industries, only those companies that learn to live with less energy will survive.

For the past several years, the trend at FVMPA has been towards energy efficiency, and recent statistics serve as evidence of the propriety of that decision. In 1978 alone, states Engineering Services Manager, **Don McQueen**, the Association spent \$326,000 on energy conservation and saved \$467,000.

Attractive payouts have been

achieved in all areas of the operation, particularly in distribution and production. Trucks were equipped both with trickle charges to increase the longevity of batteries by reducing hard starts and jet stops to shut off engines either on a signal of high temperature or low oil. Another project — the radial tire conversion — is now seventy percent complete, ultimately to yield a total ten percent saving in fuel. The changeover from steel-bodied wholesale trucks to aluminum ones has also been rewarding. "Literally, all we've done here is save on paint," explains McQueen, "but materials cost energy to make. There are just as many indirect ways of saving energy as direct ones."

In the plants, energy has been saved by converting to gas-fired heat wherever possible. For example, a gas-fired boiler was moved from

Abbotsford to Sardis to replace an oil-fired one. Two other plant projects have been initiated: hot water from the vat processor has been channelled back to the boiler room for future use, and slitted vinyl curtains over freezer doors have stopped energy in the form of steam from escaping.

However, McQueen warns, "We've mined out all the easy projects — all the gravy items. The payouts from now on will not be as immediate. Dollars spent today on energy conservation won't be recuperated for five, ten or possibly twenty years, but the fact is these dollars should be spent."

McQueen conjectures, "The end is in sight for the consumption of fossil fuels; we're in some transitional period now where there is no workable replacement for the fuels we use. Until some alternate form becomes viable, we have to be prepared to save

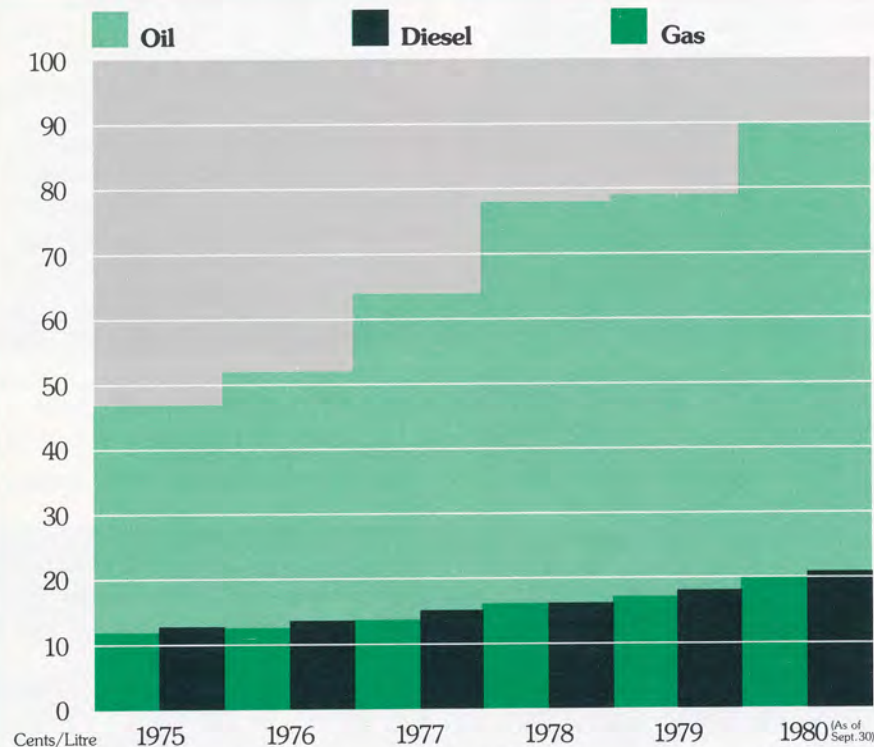

For years, pulling up to the pump was an experience with few surprises. Fuel cost increases were slow and small, seldom influencing our consumption habits. In the past five years, however, there have been some dramatic changes. Fuel costs have increased and fuel consumption has decreased; in every year from 1975 to 1980, more money had to be used to purchase less gasoline for the FVMPA fleet.

	Gasoline		Diesel		Oil	
	Litres ('000)	\$ ('000)	Litres ('000)	\$ ('000)	Litres ('000)	\$ ('000)
1980 ¹	852.8	170.8	1360.6	282.1	20.6	18.7
1979	1114.9	200.4	1618.9	290.9	27.2	20.4
1978	1251.1	198.6	1599.9	254.4	22.8	18.0
1977	1353.7	194.1	1590.5	235.1	20.7	13.2
1976	1446.1	184.1	1513.2	212.1	23.9	12.6
1975	1437.7	172.0	1466.6	186.4	25.8	12.1

¹as of September 30

energy even if it doesn't save money."

Some of these projects have already begun. A study on retail trucks has indicated a fuel saving with standard transmissions; sixteen new four-speed transmissions have already been ordered. In our Prince George and Burns Lake branches, an experiment in fifty-below weather conditions demonstrated that only vehicles with synthetic oils were able to start. This year, semi-synthetic oils will be used in all areas of the north, reducing service calls to remote locations.

Also, newly-designed heat recovery systems will enable our processing plants to use up less fuel by recycling heat previously lost up the stack.

Concludes McQueen, "We have an ongoing commitment to the federal government to reduce the growth of our energy consumption by two percent each year. There are still many more areas of conservation we need to explore."

Conservation Program

The Distribution Department has also set itself a goal — fuel savings of fifteen percent to be derived from its new Fleet Energy Conservation Program.

The program follows the findings of Distribution Manager **Bill Hawes**. "In September of this year alone," points out Hawes, "the cost of fuel rose 2.6° per litre, an increase of 13.7%. In a one-year period — August 1979 to August 1980 — fuel increased 20.7%

Milk break

Published monthly for the information of the employees of Fraser Valley Milk Producers' Association, 6800 Lougheed Highway, Burnaby, B.C.

Editor: Richard Muller,
P.O. Box 9100,
Vancouver, B.C. V6B 4G4
420-6611

INTERNATIONAL ASSOCIATION OF BUSINESS COMMUNICATORS
IN BRITISH COLUMBIA



A cold winter morning at the Sardis plant indicates some of the conditions endured by FVMPA drivers. Semi-synthetic fuels will be used in Northern branches for the first time this winter to cut down on service calls and fuel. Photo by Vivien Edwards.

in price, milk 14% and the overall cost of living 10.7%. When higher energy costs are ultimately reflected in the price of milk and milk products, our account customers' competitive positions suffer.

"Higher fuel costs could also hurt some promising markets such as retail delivery. It is likely that as two-car families decline and the automobile trip to the corner store becomes a thing of the past, the demand for home delivery will increase. But will exorbitant fuel costs mean a lack of fuel necessary to enlarge retail distribution?"

The efficiency of the distribution system, measured in the number of times a route is serviced, has always been a concern. Hawes recalls, "When the first Super Valu opened, we made as many as four calls a day there. Today, with the majority of wholesale routes serviced only three days a week or less, truck mileage, and therefore fuel consumption, have been reduced.

"But to save that extra fifteen percent, we cannot rely on the redesign of routes or trucks. The economics just aren't right for some of those alternatives. We have to work with the fleet we have. Even though buying diesel motors for home delivery trucks might be practical within the next year, present energy savings have to come from the existing fleet."

The new Fleet Energy Conservation Program has been designed with the present fleet in mind. Introduced to supervisors and then to district managers in November, the program will be given to individual drivers by the first part of next year. Farm tanker drivers will probably take the program first.

With added participation from the Garage and Maintenance department, five major areas will be discussed:

- starting and getting away
- idle control
- shifting
- road speed management
- traffic handling

Where does the current program fit in terms of an overall plan for energy efficiency? Explains Hawes, "It is an educational program intended to have drivers get the best economy out of their trucks. We can then plan a program for the supervisory group so that they can know as much as possible about the equipment."

That reiterates Don McQueen's point: "Saving energy is a fact we all need to learn."



Sammy Gray (l) is greeted by Andy Pollock. Looking on is Bill Addison and Bob Cooper (far right).



Receiving pins commemorating twenty-five years of service are Walter Neilson (l), Bob Hind, Jim Cunningham, Roy Davidson, Mike Vinter, Dorothy Smith, Doug Wilson, and Jim Defries.

One of the traditions established at the annual meeting of the Quarter Century Club is to look back twenty-five years to the year that new members first began their service with the Association. Here, along with photographs of the evening of November 17, 1980, are memories of the year 1955. Special thanks to **Verlie Bousfield** for her research.

— The last streetcar run in Vancouver was April 24, 1955.

— The minimum wage rose from seventy-five cents an hour to one dollar.

— Ann Landers began writing her newspaper column. Her sister Pauline started "Dear Abby."

— New products included Crest toothpaste and Special K.

— The birth control pill became available.

— Alan Freed coined the term "rock 'n roll." The hit song was Bill Haley's "Rock Around the Clock."

— Twenty-four-year-old James Dean starred in "Rebel Without a Cause," and was later killed in a car accident.

— Three new kid shows appeared on television — Captain Kangaroo, Howdy Doody, and The Mickey Mouse Club.

— **Jack Godfrey** of the New Westminster branch received a distinguished salesman's award from the Vancouver Board of Trade.

— A group of dieticians from Vancouver General Hospital, headed by **Paula Reber**, now the wife of **Bill Ramsell**, visited Sardis and Delair.



Photo at left shows an attentive Ron Carmichael (l), Fred Franks and Art Patterson. At right, Dorothy Smith, Sybil Norris and Ruth Schafer receive head-table bouquets from Lyle Atkinson (l), President Gordon Park and Vice President Peter Friesen.

Quarter Century Club



President Gordon Park receives honorary Club membership from retired General Manager Lyle Atkinson.



Watch recipients, from left to right, are Merle Jones, Wilmer Schmidt, Phil Stevens, Stan Johnson, Ruth Schafer, Mel Hand, Sybil Norris, Walt Moran, Marshall Currie, and George Walker.



General Manager Neil Gray congratulates Bruce Noble, age 91, the oldest Club member present.



Bill Ramsell, retired Sales Manager, centres this year's retiring Club members — Charlie Webster and Ron Bailey at left, Ken Howatt and Larry Shaw at right.



Honorary members of Club pose with President Gordon Park — Sam Brown (l), Jack Gray, Peter Wilson, and Cy Jones. Pictured at right are Cliff Cope (l), and Ben Wiens.

"Each of you will have your own memories . . . and that is what this evening is all about." (Neil Gray)



Short stories from around the Association.

Neil Gray Part of Committee

Agriculture Minister Eugene Whelan recently announced appointments to the Consultative Committee to the Canadian Dairy Commission (CDC). Among the nine members selected from across the dairy industry is FVMPA's General Manager **Neil Gray**.

The task of the Committee is to advise the CDC on matters relating to the domestic production and marketing of dairy products.

Mr. Gray will continue to serve as a director of the National Dairy Council.

Appointments

Grant Larkin, Production Manager, is pleased to announce the addition of **Bill Heath** to the production management staff. Bill now will work at the new Abbotsford plant after many years of dairy production and management experience.

Ray Hurry, General Sales Manager, is pleased to announce the appointment of **Ray Korbett** to the position of Sales Representative. Ray, who previously worked in both retail and wholesale distribution, will now be working out of the Burnaby head office.

Congratulations, Bill and Ray.

Thirsty Trick or Treaters

Results have been tabulated for this year's retail promotion of drinks held two weeks prior to Halloween. Just under 450,000 200-ml. cartons of orange, lemonade and grape drink were sold, an increase of 75% over last year.

Valley route salesmen **Dave Dixon** and **Harvey Hewitt** led all route sales, with a total of 12,331 cartons. Two pairs from Burnaby — **Joe Bazowski** and **Bob Spence**, **John Ryan** and **Ken Antifaeff** — finished second and third respectively. Of the top ten routes, six belonged to the Valley branch.

Russ Webb, Retail Manager, congratulated all the route salesmen and thanked those in the Production, Checking and Stockroom departments for their efforts and patience.



'You're a Good Man, Charlie Webster'

Recently-retired Sardis Branch Manager **Charlie Webster** and his many friends throughout the Association gathered recently in honour of his retirement. The roasting speeches provided a lot of laughter, but the highlight of the evening was a presentation from well-wishing wholesale and retail drivers of a cream can, suitably mounted, decorated and engraved. (Photo by **Vivien Edwards**.)

Farewell for Wayne Brown

Bram van Reeuyk reports from Campbell River, "A surprise farewell party was held November 7 for **Wayne Brown** and his wife Diane at the local Masonic hall. The party was well-attended with representation from all the local clubs and associations with which Wayne had been involved.

"The Campbell River Minor Hockey Association — of which Wayne was President — presented Wayne and Diane with a local painting. Presentations were also made by Campbell River Minor Softball and the local Umpires Association. Wayne was also inducted as an honorary life member of the Campbell River Minor Hockey Association."

On the Trails

The Chilliwack Fun Run and the Dairyland Cross Country Carnival were held again this fall, reports **Mike Bissell**, Marketing Representative. The Chilliwack run, organized in co-operation with the local YMCA, took three hundred participants through downtown streets. The cross country runs through Central Park in Burnaby were enjoyed by about three thousand runners and walkers, most of them from Lower Mainland schools.



Round Up

Don Hanson at the Williams Lake branch sends word — and photograph — of an ex-FVMPA employee still serving Dairyland accounts. **Egan Jensen**, who worked for the Association from 1964-1969, now owns Shoreline Services, a horse and buggy operation in Lac La Hache. He finds that his load is often comprised of Dairyland cases.

Grizzly Encounter

"We've been hikers for the last twelve years, but that's the first time anything like that has happened," states **Giselle Mortimer**, secretary at the Kitimat plant.

Giselle is referring to a day hike that she, her husband Dave and two others took on Remembrance Day deep into a remote section of the woods. As they emerged from a section of bush onto a river plain, they met a grizzly and her two cubs about one hundred yards away. When they turned to seek cover, she charged.

"The whole ordeal was over in two minutes," Giselle recalls. "The minute we stopped running and lay still, that's when the bear stopped, sniffed around awhile and then left." Giselle's husband Dave provides the moral of the story: "Do what the book says! Don't run. You can't outrun a grizzly!"



The best of the holiday season to families and friends of FVMPA staff.